

VSG1

High pressure control valve (single seat) for steam and water

Applications and design

The BTG VSG1 valves are single seat, tight shut-off throttling elements for water and steam (see fig 1).

Technical data

Type	BTG VSG1 high pressure control valve (single seat)
Manufacturer	BTG, Säffle, Sweden
Control characteristics	Equal percentage or other
Control range	40:1 60:1 for contour plug size ≥ 40 . Not applicable when pneumatic diaphragm actuator is used.
Pressure classes	PN10-320
Typical materials	See table 1
Connections	See table 4
Flanges	According to ANSI or DIN with plain flanges. Other standards on request .
Welding ends	\geq PN64 according to DIN 2559 (other standards on request).
Plug versions	
Contour plug	For water applications and steam with low pressure drop. Leakage tightness according to ANSI B16.104 Class V.
Cage plug	For steam and water applications. Leakage tightness according to ANSI B16.104 Class III-V.
Stem size (fig 2-4)	
Plug size 5-50	16 mm (0.63")
Plug size 56-180	18-45 mm (0.7-1.77")
Actuating systems	Depending on operating requirements and customer specification, the VSG1 control valve can be equipped with pneumatic, electric or electro-hydraulic actuating systems.
Weight	See table 4
Max pressure class	PN320
Max operating temperature	530°C/986°F



Fig 1 BTG VSG1 high pressure control valve with pneumatic piston actuator and integral positioner

Max operating differential pressure for water	≤ 40 bar (600 psi), hardfaced seat (HS25) standard For water applications with differential pressures above 40 bar (600 psi), see data sheet D570.01 for BTG VD multi-stage, high pressure control valve.
--	---

Materials

Table 1 Typical materials. (Customer requirements and operating conditions may determine requested material.)

Component Design temperature	Werkstoff DIN standard	~ AISI	~ B.S.	~ Swedish standard SS	Description
Body and bonnet ≤400°C/752°F ≤300°C/572°F ≤530°C/986°F	G.S. C25 1.4460 G.S. 17 CrMo55	216 WCB 329 217 WC6	592 grade A - 1504/622	SS141306 SS142324 SS142223	Carbon steel Stainless steel Low alloy steel
Stem/plug Carbon/low alloy steel valves Stainless steel valves	1.4021 1.4460	420 329	En 56C -	SS142303 SS142324	Nitrided stainless steel
Seat Carbon/low alloy steel valves Stainless steel valves	1.7335 1.4460	A182-F12 329	3604 -	SS142216 SS142324	Hardfaced HS25
Stem/plug guides Carbon/low alloy steel valves Stainless steel valves	1.8507 Monel	135 MCD	En 41B	SS142940	Nitrided steel
Stem packing	Precompressed ring of expanded graphite type Grafoil				
Bonnet gasket	Metal reinforced graphite gasket type Grafoil EX				

Plug configurations

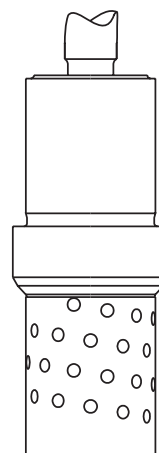
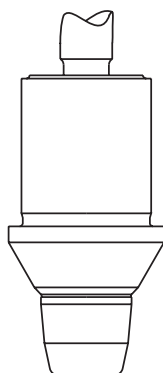
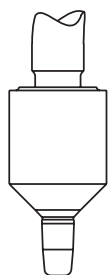

Fig 2 Plug for small K_v ,
sizes 5-20.
Flow tends to open.

Fig 3 Plug for linear charac-
teristic, sizes 28-200.
Flow tends to open.

Fig 4 Cage plug,
sizes 20-180.
Flow tends to close (water).
Flow tends to open (steam).

Capacity, areas, strokes

Table 2 Selected K_V -values for the VSG1 valves with contour plug

Plug no	Seat	Stroke	DN												
			25	40	50	65	80	100	150	200					
1	5R	19	0.5	0.5											
2	5	19	0.7	0.7											
3	7R	19	1.0	1.0											
4	7	19	1.4	1.4											
5	10R	19	2.1	2.1	2.1										
6	10	19	2.8	2.8	2.8										
7	14R	19	4.0	4.0	4.0	4.0									
8	14	19	5.3	5.5	5.5	5.5									
9	20R	19	7.6	8.4	8.4	8.4	8.4								
10	20	19	9.4	11.0	11.0	11.0	11.0								
11	28R	25		15.0	16.0	16.0	16.0	16.0							
12	28	25		19.0	21.0	22.0	22.0	22.0							
13	40R	38		26.0	30.0	33.0	33.0	33.0							
14	40	38		31.0	37.0	42.0	44.0	44.0							
15	50	38			48.0	60.0	65.0	69.0	69.0						
16	56	38				70.0	79.0	84.0	87.0						
17	72	44					110	130	140						
18	90	54						170	210	220					
19	100	60						190	250	270					
20	112	68							300	340					
21	125	75							350	410					
22	140	84							400	490					
23	160	96								600					
24	180	108								690					
25	200	120								770					

Table 3 Selected K_V -values for the VSG1 valves with cage plug (for water)

Plug no	Seat	Stroke	DN												
			25	40	50	65	80	100	150	200					
10	20	19	6.6	7.0	7.1	7.1	7.1	7.1							
12	28	25		15.1	15.6	15.9	15.9	16.0							
14	40	38		26.0	29.1	30.9	31.5	31.8							
15	50	38			42.5	48.7	51.3	52.5	53.3						
16	56	38				56.8	60.9	63.1	64.4						
17	72	44					83.6	89.6	93.5						
18	90	54						134	148	151					
19	100	60						159	184	190					
20	112	68							222	232					
21	125	75							269	288					
22	140	84							319	351					
23	160	96								449					
24	180	108								546					

For steam applications, the K_V -values might change because of the compressibility of the steam.

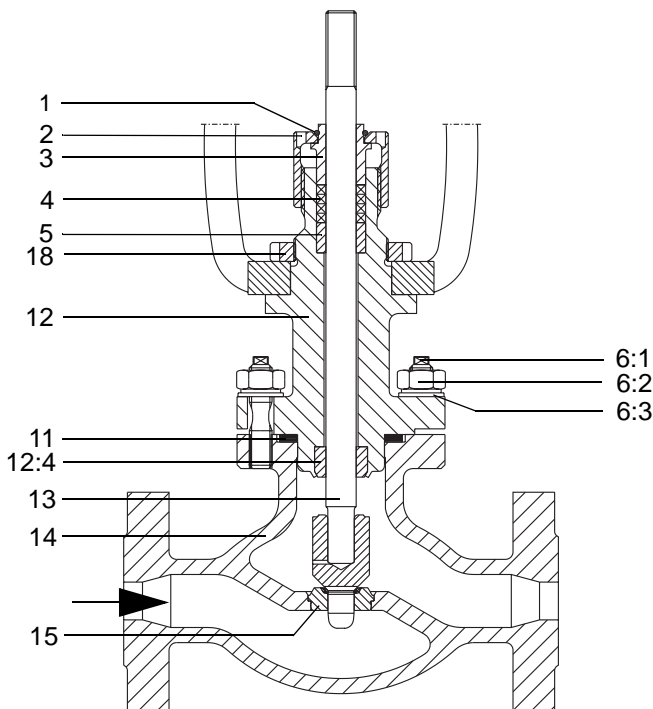

Fig 5 Seat ≤ 20

- | | | | |
|---|--------------|-----|-----------------|
| 1 | Snap ring | 5 | Stem guide bush |
| 2 | Gland nut | 6:1 | Screw |
| 3 | Gland | 6:2 | Nut |
| 4 | Stem packing | 6:3 | Washer |

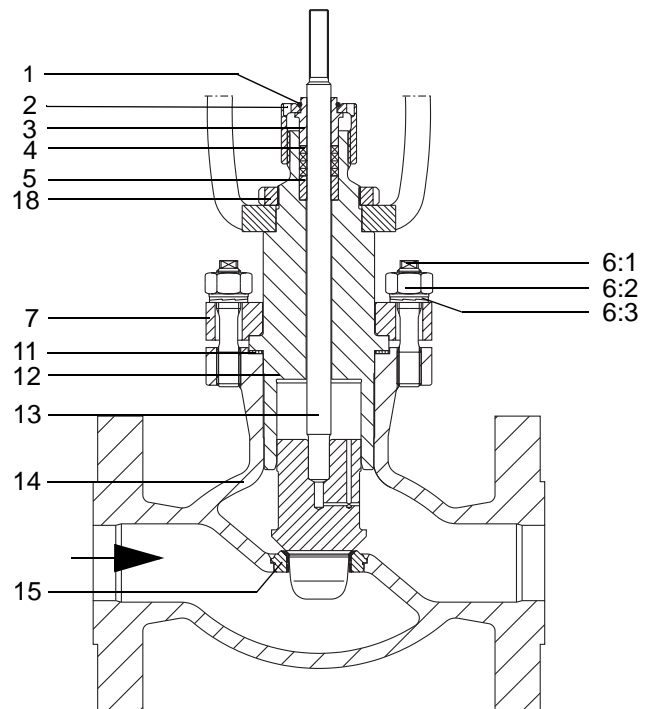

Fig 6 Seat ≥ 28

- | | | | |
|------|-----------------|----|-----------|
| 7 | Bonnet flange | 13 | Stem/plug |
| 11 | Gasket | 14 | Body |
| 12 | Bonnet | 15 | Seat |
| 12:4 | Stem guide bush | 18 | Lock nut |

Dimensions and weights

Table 4 Dimensions (fig 7) and weights

PN bar	Size		Face to face dimensions				Height of valve		Weight without actuator			
			Flange L1		Welding ends L2		H		Flange		Welding ends	
	mm	~ in	mm	~ in	mm	~ in	mm	~ in	kg	~ lbs	kg	~ lbs
10-40	65	2.5	290	11.4	-	-	200	7.9	50	111	-	-
	80	3	310	12.2	-	-	200	7.9	65	144	-	-
	100	4	350	13.8	-	-	240	9.5	80	178	-	-
	150	6	480	18.9	-	-	330	13.0	170	377	-	-
64-160	25	1	230	9.0	230	9.0	162	6.4	35	78	30	67
	40	1.5	260	10.2	260	10.2	183	7.2	45	100	40	89
	50	2	300	11.8	300	11.8	220	8.7	55	122	48	107
	65	2.5	340	14.4	340	14.4	250	9.8	65	144	55	122
	80	3	380	15.0	380	15.0	270	10.6	75	167	68	151
	100	4	430	16.9	430	16.9	300	11.8	90	200	75	167
	150	6	550	21.6	550	21.6	390	15.4	180	400	165	366
250-320	25	1	260*	10.2	260	10.2	235	9.3	45	100	40	89
	40	1.5	300	11.8	300	11.8	280	11.0	60	133	53	118
	50	2	380	15.0	380	15.0	300	11.8	75	167	65	144
	65	2.5	400	15.7	400	15.7	320	12.6	90	200	75	167

* With flange according to ANSI 900-1500
 L1 = 276. For sizes > 125, 1.0 m free height
 is needed for removal of the plug. For installation of
 actuating systems, drawings are available from
 BTG on request.

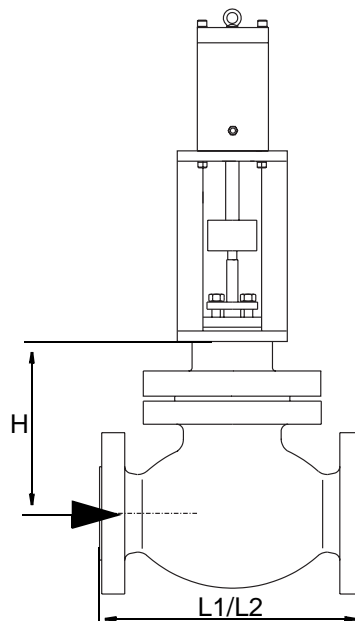

Fig 7 Main dimensions of VSG1

Grupo Compás. C/ Padilla 312, 2º 2ª. 08025 Barcelona. Spain.

Tlf.: (+34) 93 435 1672...Fax: (+34) 93 550 4076. Email: grupocompas@grupocompas.es