

LADISH

CORROSION RESISTANT

VALVES

Gate • Globe • Check

CRYOGENIC



TO MARK PROGRESS



LADISH VALVE COMPANY, LLC

7612 Bluff Point Drive, Houston, Texas 77086

Phone: 1.866.523.4740 or 281.880.8560 Fax: 281.880.8061

Web: www.ladishvalves.com Email: sales@ladishvalves.com

LV-CRYO-2013



LADISH VALVES

INSIDE LADISH

HISTORY

LADISH VALVES® have been produced in the U.S.A. for more than half a century. LADISH is recognized as the premier manufacturer of stainless steel Cryogenic Valves. With a large product range and source foundries located in the U.S.A., LADISH can provide a high-quality product with a quick delivery. LADISH is located in Houston, Texas and serves as the sole headquarters for all engineering, manufacturing, sales, parts, and services.

FOUNDING PRINCIPLES

LADISH VALVES® principle business activities include manufacturing valves to strict specifications and industry standards. LADISH maintains and controls extensive inventory levels of stainless and high nickel alloy. LADISH is committed to continual product improvement through research development and quality customer support.



TABLE OF CONTENTS

- **Components & Materials.....3-4**
- **Gate Valves.....5-6**
- **Globe Valves.....7-8**
- **Check Valves.....9-10**
- **Contact Us.....11**



COMPONENTS & MATERIALS OF CONSTRUCTION

LADISH VALVES

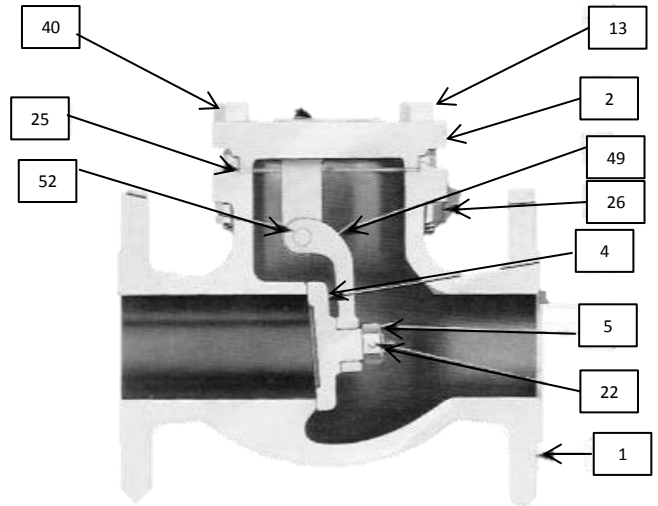
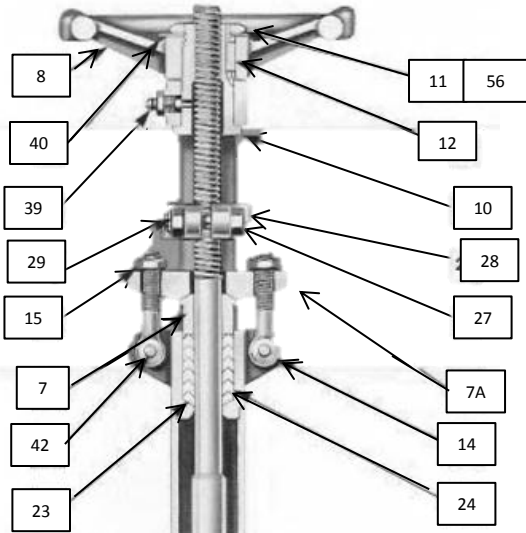

TYPICAL CRYOGENIC SWING CHECK VALVE

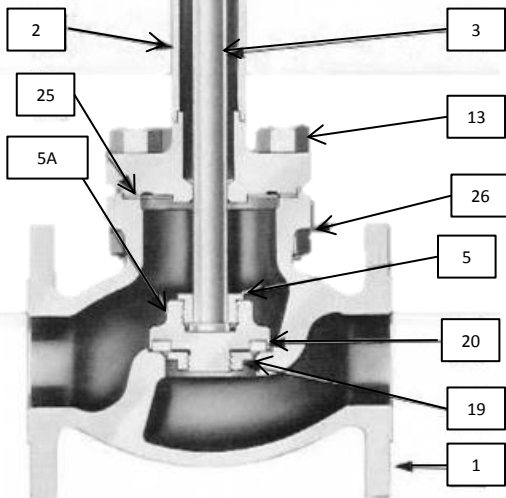

TYPICAL CRYOGENIC GLOBE VALVE

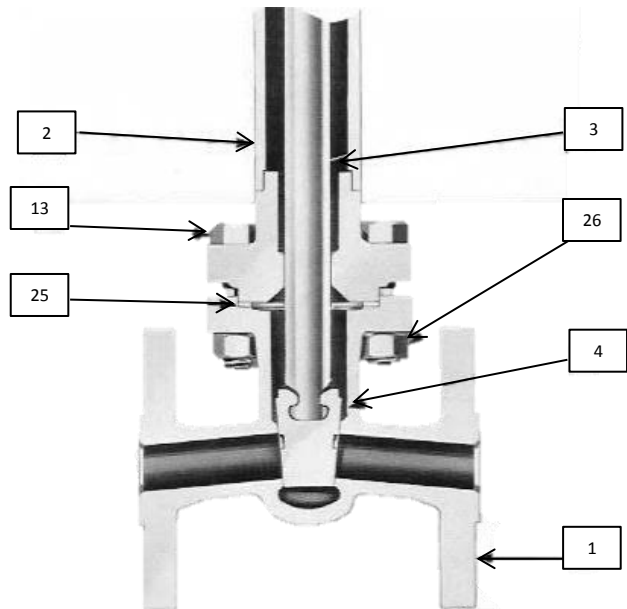

TYPICAL CRYOGENIC GATE VALVE



COMPONENTS & MATERIALS OF CONSTRUCTION

LADISH VALVES

No.	Component	TYPICAL GATE, GLOBE AND SWING CHECK VALVE—CF8M†			
		GATE AND GLOBE VALVE		SWING CHECK VALVE	
		Material	Specification	Material	Specification
1	Body Flanged End	316 SS	ASTM A351 CF8M	316 SS	ASTM A351 CF8M
1	Body Threaded, Socket or Butt Weld End	316L SS	ASTM A351 CF3M	316L SS	ASTM A351 CF3M
2	Bonnet Weld Assembly*	316 SS	ASTM A351 CF8M	—	—
2	Cover	—	—	316 SS	ASTM A351 CF8M
3	Stem	316 SS	ASTM A276 316	—	—
4	Disc	316 SS	ASTM A351 CF8M	316 SS	ASTM A351 CF8M
5	Disc Nut	316 SS	ASTM A276 316	316 SS	ASTM A194 GR. 8M
5A	Disc Holder	316 SS	ASTM A351 CF8M	—	—#
7	Gland	316 SS	ASTM A276 316	—	—
7A	Gland Yoke	304 SS	ASTM A351 CF8	—	—
8	Handwheel	Malleable Iron	ASTM A47	—	—
10	Stem Nut	303 SS	ASTM A582 T303	—	—
11	Stem Nut Lock Nut	304 SS	ASTM A351 CF8	—	—
12	Stem Nut Key	Carbon Steel	AISI C1018	—	—
13	Bonnet / Cover Bolt	304 SS	ASTM A320 Gr B8	304 SS	ASTM A320 Gr. B8
14	Gland Eyebolt	304 SS	ASTM A193 Gr B8	—	—
15	Gland Eyebolt Nut	303 SS	ASTM A194 Gr 8F	—	—
19	Disc Holder Nut	316 SS	ASTM A276 F316	—	—
20*	Renewable Disc Insert	Teflon	Teflon	—	—
22	Disc Nut Lock Pin	-	-	316 SS	ASTM A182 F316
23*	Packing Adapter	Teflon	Teflon	—	—
24*#	Packing	Teflon	Teflon	—	—
25*	Bonnet / Cover Gasket	Teflon	Teflon	Teflon	Teflon
26	Bonnet / Cover Bolt Nut	304 SS	ASTM A194 Gr 8A	304 SS	ASTM A194 Gr 8A
27	Stem Clamp	304 SS	ASTM A182 F304	—	—
28	Stem Clamp Bolt	304 SS	ASTM A193 Gr B8	—	—
29	Stem Clamp Nut	304 SS	ASTM A194 Gr 8F	—	—
39	Grease Fitting	316 SS	AISI 316	—	—
40	Identification Plate	304 SS	A240 304	304 SS	A240 304
42	Eyebolt Pin	303 SS	ASTM A582 T303	—	—
49	Arm	-	-	316 SS	ASTM A351 CF8M
52	Hinge Pin	-	-	316 SS	ASTM A276 316
56	Set Screw	304 SS	ASTM A182 F304	—	—

† Specification on other materials available on request.

*Recommended spare parts.

#Graphite packing available on request.

*Extended Bonnet Fabrication Welds are made in

Accordance with ANSI/ASME B31.3 Provision.



LADISH VALVES

GATE VALVE

® O.S.&Y EXTENDED BOLTED BONNET

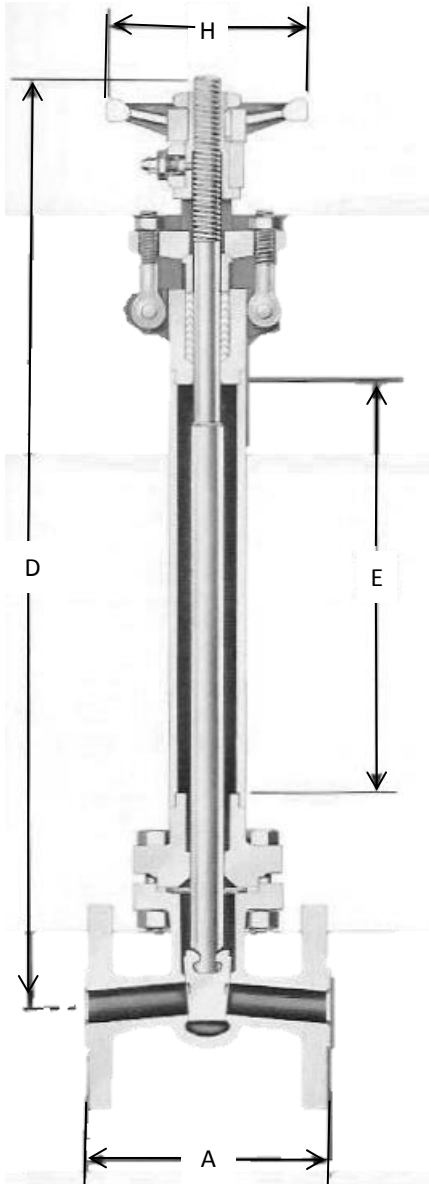

Solid Wedge Disc

Split Wedge Disc

VALVE DESCRIPTION				
CRYOGENIC GATE VALVES				
O.S.&Y. EXTENDED BOLTED BONNET				
CLASS			END	DISC
150	300	600		
No. 8290	—	—	Threaded	Split Wedge
No. 8291	—	—	Socket Weld	Split Wedge
No. 8292	—	—	Flanged	Split Wedge
No. 8293	No. 8393	No. 8693	Threaded	Solid Wedge
No. 8294	No. 8394	No. 8694	Socket Weld	Solid Wedge
No. 8295	No. 8395	No. 8695	Flanged	Solid Wedge
No. 8296	—	—	Butt Weld	Split Wedge
No. 8299	No. 8399	No. 8699	Butt Weld	Solid Wedge
STANDARDS AND SPECIFICATIONS				
RATING	MATERIAL ASTM A351 CF8M (TYPE 316SS)			
	Temperature Range of +100°F to -325°F			
	Class 150	Class 300	Class 600	
	275 PSIG	720 PSIG	1440 PSIG	
PACKING	Teflon packing rings are standard for service up to 500°F.			
GASKET	Teflon gasket is standard. Grafoil gaskets are optional. Teflon gaskets are furnished for service up to 500°F.			
MATERIAL	Normally stocked in CF8M (Type 316SS). Threaded, socket and butt weld end stainless steel valve bodies are low carbon grade material. Stainless steel stem nut and locknut is standard.			
STANDARDS	<p>Dimensions are in inches. Weights are in pounds.</p> <p>Pipe threads conform to ANSI B2.1</p> <p>Socket weld end dimensions conform to ANSI B16.11.</p> <p>Butt weld ends conform to ANSI B16.25</p> <p>End flange diameter, thickness, facing, diameter of bolt circle, number and diameter of bolt holes for Class 150 conform to MSS SP-42 for NPS ½" and NPS ¾", NPS 1" and larger for Class 150, and all sizes in Class 300 and 600 conform to ANSI B16.5.</p> <p>1/16" raised face is standard for Class 150 and 300 flanged and valves 1/4" raised face is standard for Class 600 flanged end valves. Gasket surface finish is spiral serrated per MSS SP-6. Other facings can be furnished.</p> <p>End-to-end dimensions for flanged and butt weld end valves conform to ANSI B16.10.</p>			
DESIGN	<p>Class 150 flanged end valves NPS ½" and NPS ¾" are designed in accordance with MSS SP-42 and are rated accordingly. Class 150 butt weld end valves NPS ½" and NPS ¾" are designed parallel to MSS SP-42 and are rated accordingly. Class 150 flanged and butt weld end valves NPS 1" and larger, and all Class 300 and 600 flanged end valves are designed in accordance with ANSI B16.34.</p> <p>Valves have non-rising handwheel.</p>			
GAS COLUMN	Unless otherwise specified, gas column length will be furnished as listed. Other gas column lengths can be furnished.			
OPTIONS	Other packing, gaskets and materials than listed above are available.			



GATE VALVE

O.S.&Y EXTENDED BOLTED BONNET

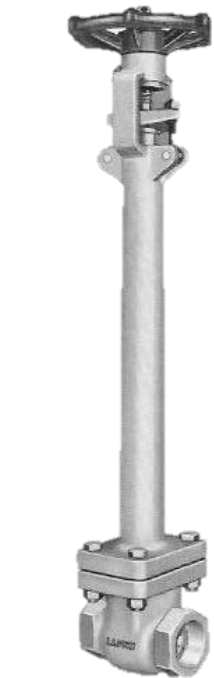
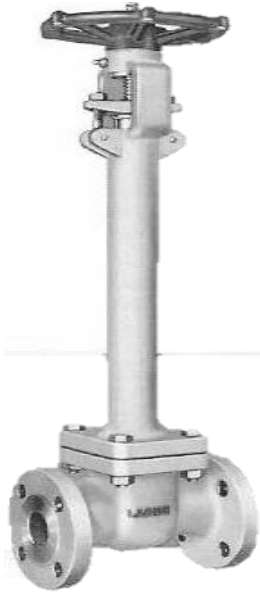

End-to-End A			Open Height D	Gas Column E	Handwheel Diameter H	Weight		
Threaded and Socket	Flanged	Butt Weld				Threaded and Socket	Flanged	Butt Weld
2 3/4	4 1/4	4 1/4	16 3/4	7	3 1/2	7	10	7
2 7/8	4 5/8	4 5/8	16 3/4	7	3 1/2	7	11	8
3 1/2	5	5	21	10	4 7/8	12	16	13
4 1/4	6 1/2	6 1/2	24	10	6 1/2	22	28	20
5	7	8 1/2	26 1/4	10	6 1/2	26	35	29
—	7 1/2	9 1/2	30 1/4	12	7 1/2	—	52	42
—	8	11 1/8	34 1/2	14	7 1/2	—	62	48
—	9	12	44	16	9	—	102	83
—	10 1/2	15 7/8	51	18	11	—	167	165
—	11 1/2	16 1/2	60 1/2	21	13 1/2	—	323	255
—	13	18	76 1/4	24	16	—	500	395
—	14	19 3/4	85	27	19	—	720	568
2 3/4	5 1/2	—	20 3/4	7	4 7/8	12	19	—
3 1/4	6	—	20 3/4	7	4 7/8	14	20	—
3 3/4	6 1/2	—	24 3/4	10	6 1/2	21	32	—
5	7 1/2	—	27 5/8	10	7 1/2	42	56	—
5 3/4	8 1/2	—	28 7/8	10	7 1/2	57	68	—
—	9 1/2	—	35	12	9	—	110	—
—	11 1/8	—	39 1/2	14	11	—	145	—
—	12	—	47 1/4	16	13 1/2	—	244	—
—	15 7/8	—	57 1/2	18	16	—	400	—
—	16 1/2	—	68 3/4	21	19	—	702	—
—	18	—	80 7/8	24	19	—	855	—
—	19 3/4	—	90	27	23 1/2	—	1025	—
2 3/4	6 1/2	—	20 1/2	7	4 7/8	13	19	—
3 1/4	7 1/2	—	20 3/4	7	4 7/8	14	20	—
3 3/4	8 1/2	—	23	10	6 1/2	21	32	—
5	9 1/2	—	26 3/4	10	7 1/2	42	61	—
5 3/4	11 1/2	—	28 3/4	10	7 1/2	57	74	—
—	14	—	40 5/8	14	11	—	165	—
—	17	—	47 3/4	16	13 1/2	—	256	—
—	22	—	60 3/4	18	19	—	455	—
—	26	—	74 3/8	21	23 1/2	—	862	—

CLASS	DISC	THREADED	SOCKET WELD	FLANGED	BUTT WELD
150	Split Wedge	No. 8290	No. 8291	No. 8292	No. 8296
	Solid Wedge	No. 8293	No. 8294	No. 8295	No. 8299
300	Split Wedge	—	—	—	—
	Solid Wedge	No. 8393	No. 8394	No. 8395	No. 8399
600	Split Wedge	—	—	—	—
	Solid Wedge	No. 8693	No. 8694	No. 8695	No. 8699



GLOBE VALVE

O.S.&Y EXTENDED BOLTED BONNET

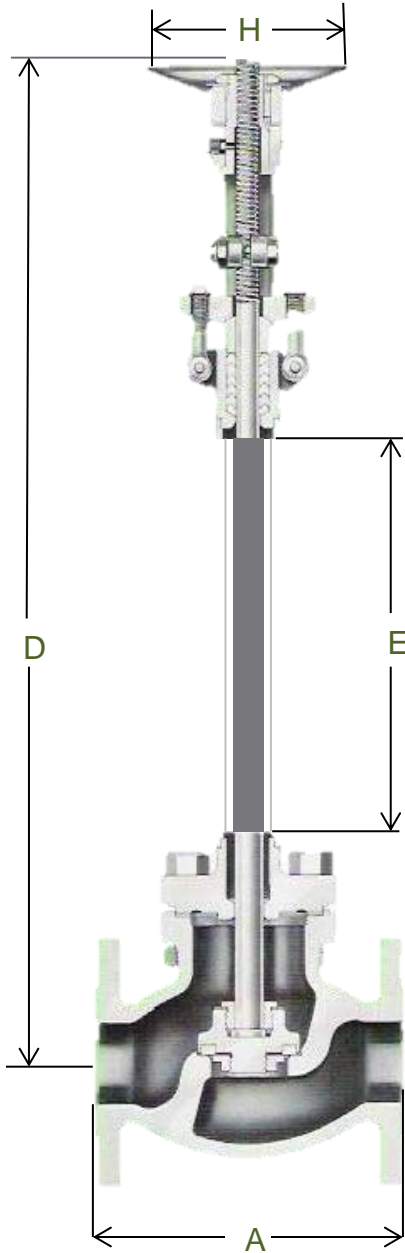

Metal Plug Disc



Renewable Disc

VALVE DESCRIPTION				
CRYOGENIC GLOBE VALVES				
O.S.&Y. EXTENDED BOLTED BONNET				
CLASS			END	DISC
150	300	600		
No. 7290	No. 7390	No. 7690	Threaded	Metal Plug
No. 7291	No. 7391	No. 7691	Socket Weld	Metal Plug
No. 7292	No. 7392	No. 7692	Flanged	Metal Plug
No. 7293	No. 7393	No. 7693	Threaded	Renewable
No. 7294	No. 7394	No. 7694	Socket Weld	Renewable
No. 7295	No. 7395	No. 7695	Flanged	Renewable
No. 7296	No. 7396	No. 7696	Butt Weld	Metal Plug
No. 7299	No. 7399	No. 7699	Butt Weld	Renewable
STANDARDS AND SPECIFICATIONS				
RATING	MATERIAL ASTM A351 CF8M (TYPE 316SS)			
	Temperature Range of +100°F to -325°F			
	Class 150	Class 300	Class 600	
	275 PSIG	720 PSIG	1440 PSIG	
PACKING	Teflon packing rings are standard for service up to 500°F.			
GASKET	Teflon gasket is standard. Grafoil and Kel-F can be furnished.			
MATERIAL	Normally stocked in CF8M (Type 316SS). Threaded, socket and butt weld end stainless steel valve bodies are low carbon grade material. Stainless steel stem nut and locknut is standard. Renewable discs are a composite of the same grade material as the valve and renewable disc insert of Teflon for service up to 500 F. KEL-F available. KEL-F standard on 300#, 600#			
STANDARDS	Dimensions are in inches. Weights are in pounds. Pipe threads conform to ANSI B2.1 Socket end dimensions conform to ANSI B16.11. Butt weld ends conform to ANSI B16.25 End flange diameter, thickness, facing, diameter of bolt circle, number and diameter of bolt holes for Class 150 conform to MSS SP-42 for NPS ½" and NPS ¾". NPS 1 and larger for Class 150, and all sizes in Class 300 and 600 conform to ANSI B16.5. 1/16" raised face is standard for Class 150 and 300 flanged end valves ¼" raised face is standard for Class 600 flanged end valves. Gasket surface finish is spiral serrated per MSS SP-6. Other facings can be furnished. End-to-end dimensions for flanged and butt weld end valves conform to ANSI B16.10.			
DESIGN	Class 150 flanged end valves NPS ½" and NPS ¾" are designed in accordance with MSS SP-42 and are rated accordingly. Class 150 flanged and butt weld end valves NPS 1" and larger, and a Class 300 and 600 flanged end valves are designed in accordance with ANSI B16.34 Valves may have rising or non-rising handwheel.			
GAS COLUMN	Unless otherwise specified, gas column length will be furnished as listed. Other gas column lengths can be furnished.			
OPTIONS	Other packing, gaskets and materials than listed above are available			



GLOBE VALVE

O.S.&Y EXTENDED BOLTED BONNET



CLASS	Nom. Pipe Size	End-to-End A			Open Height D	Gas Column E	Handwheel Diameter H	Weight		
		Threaded and Socket	Flanged	Butt Weld				Threaded and Socket	Flanged	Butt Weld
150	1/2	3 3/8	4 1/4	—	18 5/8	7	3 1/2	9	12	—
	3/4	3 3/4	4 5/8	—	18 5/8	7	3 1/2	10	13	—
	1	4 1/4	5	5	24 1/4	10	4 7/8	17	21	15
	1 1/2	5 3/4	6 1/2	6 1/2	25	10	6 1/2	22	27	25
	2	6 1/4	8	8	26	10	6 1/2	32	33	30
	2 1/2	—	8 1/2	8 1/2	29	12	7 1/2	—	63	44
	3	—	9 1/2	9 1/2	33 1/2	14	7 1/2	—	84	72
	4	—	11 1/2	11 1/2	40 1/4	16	11	—	136	116
	6	—	16	16	45 1/2	18	13 1/2	—	275	230
	8	—	19 1/2	—	54	21	16	—	400	—
10	—	24 1/2	—	65	24	19	—	650	—	
300	1/2	3 3/4	6	—	20 1/4	7	4 7/8	11	15	—
	3/4	4 1/4	7	—	20 1/4	7	4 7/8	15	18	—
	1	5	8	—	24 3/8	10	6 1/2	18	27	—
	1 1/2	6	9	—	26 5/8	10	7 1/2	33	48	—
	2	7 1/4	10 1/2	—	28 1/2	10	7 1/2	47	61	—
	2 1/2	—	11 1/2	—	31	12	11	—	94	—
	3	—	12 1/2	—	33 7/8	14	13 1/2	—	120	—
4	—	14	—	39 5/8	16	13 1/2	—	170	—	
6	—	17 1/2	—	49	18	16	—	335	—	
600	1/2	3 3/4	6 1/2	—	20 1/4	7	4 7/8	12	16	—
	3/4	4 1/4	7 1/2	—	20 1/4	7	4 7/8	17	22	—
	1	5	8 1/2	—	24 3/8	10	6 1/2	22	29	—
	1 1/2	6	9 1/2	—	26 5/8	10	7 1/2	33	48	—
	2	7 1/4	11 1/2	—	28 1/2	10	7 1/2	47	76	—
	2 1/2	—	13	—	39	12	11	—	140	—
	3	—	14	—	40 1/2	14	13 1/2	—	160	—
	4	—	17	—	49	16	16	—	315	—
6	—	22	—	59	18	19	—	615	—	

CLASS	DISC	THREADED	SOCKET WELD	FLANGED	BUTT WELD
150	Metal Plug	No. 7290	No. 7291	No. 7292	No. 7296
	Renewable	No. 7293	No. 7294	No. 7295	No. 7299
300	Metal Plug	No. 7390	No. 7391	No. 7392	No. 7396
	Renewable	No. 7393	No. 7394	No. 7395	No. 7399
600	Metal Plug	No. 7690	No. 7691	No. 7692	No. 7696
	Renewable	No. 7693	No. 7694	No. 7695	No. 7699



LADISH VALVES

SWING CHECK VALVE BOLTED COVER

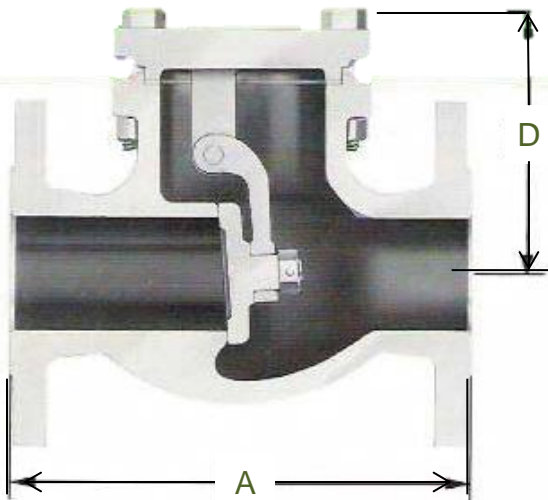

Metal Disc



Renewable Disc

VALVE DESCRIPTION				
CRYOGENIC SWING CHECK VALVES BOLTED COVER				
CLASS			END	DISC
150	300	600		
No. 5290	No. 5390	No. 5690	Threaded	Metal
No. 5291	No. 5391	No. 5691	Socket Weld	Metal
No. 5292	No. 5392	No. 5692	Flanged	Metal
No. 5293	No. 5393	No. 5693	Threaded	Renewable
No. 5294	No. 5394	No. 5694	Socket Weld	Renewable
No. 5295	No. 5395	No. 5695	Flanged	Renewable
No. 5296	No. 5396	No. 5696	Butt Weld	Metal
No. 5299	No. 5399	No. 5699	Butt Weld	Renewable
STANDARDS AND SPECIFICATIONS				
RATING	MATERIAL ASTM A351 CF8M (TYPE 316SS)			
	Temperature Range of +100°F to -325°F			
	Class 150 275 PSIG	Class 300 720 PSIG	Class 600 1440 PSIG	
GASKET	Teflon gasket is standard. Grafoil and Kel-F can be furnished.			
MATERIAL	Normally stocked in CF8M (Type 316SS). Threaded, socket and butt weld end stainless steel valve bodies are low carbon grade material. Renewable discs are a composite of the same grade material as the valve and renewable disc insert of Teflon for service up to 500 F. KEL-F available. KEL-F standard on 300#, 600#			
STANDARDS	Dimensions are in inches. Weights are in pounds. Pipe threads conform to ANSI B2.1 Socket weld end dimensions conform to ANSI B16.11. Butt weld ends conform to ANSI B16.25 End flange diameter, thickness, facing, diameter of bolt circle, number and diameter of bolt holes for Class 150 conform to MSS SP-42 for NPS 1/2 and NPS 3/4. NPS 1 and larger for Class 150, and all sizes in Class 300 and 600 conform to ANSI B16.5. 1/16" raised face is standard for Class 150 and 300 flanged and valves. 1/4" raised face is standard for Class 600 flanged end valves. Gasket surface finish is spiral serrated per MSS SP-6. Other facings can be furnished. End-to-end dimensions for flanged and butt weld end valves conform to ANSI B16.10.			
DESIGN	Class 150 flanged end valves NPS 1/2 and NPS 3/4 are designed in accordance with MSS SP-42 and are rated accordingly. Class 150 flanged and butt weld end valves NPS 1 and larger, and a Class 300 and 600 flanged end valves are designed in accordance with ANSI B16.34			
OPTIONS	Other gasket and materials than listed above are available.			



LADISH VALVES

SWING CHECK VALVE BOLTED COVER



End-to-End A			Center-to-Top D		Weight		
Threaded and Socket and Socket	Flanged	Butt Weld	Threaded and Socket and Socket	Flanged and Butt Weld	Threaded and Socket	Flanged	Butt Weld
3 5/8	4 1/4	—	2 7/8	3	3	5	—
3 5/8	4 5/8	—	2 7/8	3	3	5	—
4	5	5	2 7/8	3	4	7	8
5 7/8	6 1/2	6 1/2	4 3/8	4 3/8	12	17	13
6 1/4	8	8	4 5/8	4 5/8	15	28	21
—	8 1/2	8 1/2	—	5 1/4	—	43	29
—	9 1/2	9 1/2	—	6 1/4	—	55	43
—	11 1/2	11 1/2	—	7 1/4	—	87	63
—	14	14	—	9	—	160	112
—	19 1/2	—	—	9 7/8	—	348	—
—	24 1/2	—	—	12 1/2	—	590	—
—	27 1/2	—	—	14 3/8	—	870	—
3 5/8	6	—	3 1/4	3 1/2	7	10	—
3 5/8	7	—	3 1/4	3 5/8	7	13	—
4	8 1/2	—	3 1/2	3 7/8	9	17	—
5 7/8	9 1/2	—	5 1/2	5 1/2	28	42	—
6 1/4	10 1/2	—	6 1/4	5 1/2	30	43	—
—	11 1/2	—	—	6 3/8	—	58	—
—	12 1/2	—	—	6 3/4	—	86	—
—	14	—	—	7 5/8	—	124	—
—	17 1/2	—	—	10 1/2	—	260	—
—	21	—	—	12 1/4	—	472	—
—	24 1/2	—	—	15	—	800	—
—	28	—	—	17 1/4	—	1140	—
3 5/8	6 1/2	—	3 1/4	3 5/8	7	10	—
3 5/8	7 1/2	—	3 1/4	3 5/8	7	13	—
4	8 1/2	—	3 1/2	3 7/8	9	17	—
5 7/8	9 1/2	—	5 1/2	6	28	44	—
6 1/4	11 1/2	—	6 1/4	6 1/4	30	47	—
—	13	—	—	7 3/4	—	72	—
—	14	—	—	8 7/8	—	136	—
—	17	—	—	10 1/4	—	205	—
—	22	—	—	12 5/8	—	456	—

CLASS	DISC	THREADED	SOCKET WELD	FLANGED	BUTT WELD
150	Metal	No. 5290	No. 5291	No. 5292	No. 5296
	Renewable	No. 5293	No. 5294	No. 5295	No. 5299
300	Metal	No. 5390	No. 5391	No. 5392	No. 5396
	Renewable	No. 5393	No. 5394	No. 5395	No. 5399
600	Metal	No. 5690	No. 5691	No. 5692	No. 5696
	Renewable	No. 5693	No. 5694	No. 5695	No. 5699



LADISH VALVES

CONTACT US

- Please call LADISH with any inquiries or valve related questions

General Manager	Bill DiStefano	bdistefano@ladishvalves.com
Production Manger	Aaron DiStefano	adistefano@ladishvalves.com
Quality Manager	Todd Haberkost	thaberkost@ladishvalves.com
Inside Sales	Bob King	bking@ladishvalves.com
Outside Sales	Toby Tinelli	ttinelli@ladishvalves.com

7612 Bluff Point Drive, Houston, Texas 77086

Phone: 1.866.523.4740 or 281.880.8560 Fax:281.880.8061

Web:www.ladishvalves.com Email:sales@ladishvalves.com

Published technical data and general information are intended solely for the coverage of typical applications for users of LADISH products featured in this catalog. Please contact LADISH Company, LLC for specific questions, technical assistance, or to produce your own study, data, and conclusions related to the quality and performance of our products to a specific application. LADISH Company, LLC is not responsible for property damage and or personal injury that may result from failure to follow these instructions. Any information listed in this brochure is subject to change with regard to time sensitivity, error correction, product and design introduction, modification or discontinuation, as well as any other changes LADISH Company, LLC, considers appropriate.