

ALOYCO

Corrosion Resistant Valves



THE FIRST NAME IN CORROSION RESISTANT VALVES

CRANE
THE VALVE EXPERTS

Stainless Steel Valves

General Index

Figure No.	Valve Type	Pressure Class	End Connection	Material Available	Size Range	Catalog Page
90	Gate, RS	200 CWP	Threaded	CF8M	½" - 2"	5
190	Gate, NRS	200 CWP	Threaded	CF8M	½" - 2"	5
110	Gate, OS&Y	150	Threaded	CF3M	½" - 2"	6
114	Gate, OS&Y	150	Socket Weld	CF3M	½" - 2"	6
117, 117F	Gate, OS&Y	150	Flanged	CF8M	½" - 24"	7
2110	Gate, OS&Y	300	Threaded	CF3M	½" - 2"	8
2114	Gate, OS&Y	300	Socket Weld	CF3M	½" - 2"	8
2117, 2117F	Gate, OS&Y	300	Flanged	CF8M	½" - 24"	9
4210	Gate, OS&Y	600	Threaded	CF3M	½" - 2"	10
4214	Gate, OS&Y	600	Socket Weld	CF3M	½" - 2"	10
4217, 4117F	Gate, OS&Y	600	Flanged	CF8M	½" - 24"	11
40	Globe	200 CWP	Threaded	CF8M	½" - 2"	12
310	Globe	150	Threaded	CF3M	½" - 2"	13
314	Globe	150	Socket Weld	CF3M	½" - 2"	13
317	Globe	150	Flanged	CF8M	½" - 12"	14
2310	Globe	300	Threaded	CF3M	½" - 2"	15
2314	Globe	300	Socket Weld	CF3M	½" - 2"	15
2317	Globe	300	Flanged	CF8M	½" - 8"	16
4310	Globe	600	Threaded	CF3M	½" - 2"	17
4314	Globe	600	Socket Weld	CF3M	½" - 2"	17
4317	Globe	600	Flanged	CF8M	½" - 6"	18
49	Swing Check	200 CWP	Threaded	CF8M	½" - 2"	19
370	Swing Check	150	Threaded	CF3M	½" - 2"	20
374	Swing Check	150	Socket Weld	CF3M	½" - 2"	20
377	Swing Check	150	Flanged	CF8M	½" - 24"	21
2370	Swing Check	300	Threaded	CF3M	½" - 2"	22
2374	Swing Check	300	Socket Weld	CF3M	½" - 2"	22
2377	Swing Check	300	Flanged	CF8M	½" - 24"	23
4370	Swing Check	600	Threaded	CF3M	½" - 2"	24
4374	Swing Check	600	Socket Weld	CF3M	½" - 2"	24
4377	Swing Check	600	Flanged	CF8M	½" - 12"	25
9502	Ball - 2 pc	2000 CWP	Threaded	CF8M	¼" - 2"	26

Stainless Steel Valves

How To Order

How to Specify and Order the Correct Valves

This catalog has been published to assist you in choosing the correct valve for a vast number of piping conditions. The Aloyco product line makes available to you a very broad choice of valves. These valves are described in this catalog.

Care should be taken to select the most suitable valves for your service(s). Exact specification of each valve should be made to avoid possible ambiguity. When requesting quotations and/or ordering the product a fully adequate description should be made.

Selecting the Valve Size

Nominal size of the pipeline into which the valve will be placed must be determined.

Valve Material

The following facts should be considered in determining the correct valve material:

- the medium or media which will be controlled
- the temperature range of the line medium (media)
- the pressure range to which the valve will be subjected
- possible atmospheric conditions which may affect the valve
- possible extraordinary stresses to which the valve will be subjected
- safety standards and/or piping codes which must be met

Type of Valve

What is the control function of the valve? Each valve configuration has been developed to perform certain control functions. Do not expect one type of valve to perform all the valving jobs in a system.

Pressure-Temperature Ratings

Please pay careful attention that the pressure-temperature ratings of a particular valve are in keeping with the requirements of the service. Pay especially careful attention to the packing and gasket materials as this may limit the rating as is the case with PTFE used as the standard in Aloyco valves. Specify alternative packing and/or gasket materials as necessary to meet or exceed your service requirements.

Valve and Connections

Considerations as to pipeline integrity, future maintenance, corrosion factors, field assembly, weight and safety should be given in determining the method of connecting the valve in the pipeline.

Method of Operation

The means by which the valve is operated as supplied are shown for the valves in this catalog. Many optional operating devices are regularly supplied by Aloyco.

Ordering the Valve

Please state the following information when ordering a valve in order to avoid unnecessary delays and to insure we supply you with the valve you have requested.

1. Valve size
2. Pressure boundary material - metallurgy of the castings and components.
3. Type of valve - gate, globe, check, etc.
4. End connection including wall thickness of connecting pipe if weld end and any special flange facings or finishes
5. Any material deviations from standard - packing, gasket, bolting, etc.
6. Any accessories - acid shield, locking devices, chain operation, etc.
7. Manual or power actuators, please include details of requirements.
8. For convenience in ordering, specify by figure number.

Contact Aloyco for additional assistance in valve selection.

Stainless Steel Gate Valves

200 CWP • Threaded Bonnet • Solid Wedge Disc

Figure 90

Rising Stem

Figure 190

Non-Rising Stem

Size Range:

1/2 through 2 inches

Design Features:

- Threaded Ends
- Integral Seat
- Figure 190 - Inside Screw/Non-rising Stem

Pressure Temperature Ratings:

200 psi @ -20 to 100°F

135 psi @ 500°F

Industry Standards

Threaded Ends	ASME B1.20.1
End-to-End	Manufacturer's Standard

Materials of Construction

1	Body	ASTM A351 CF8M
2	Bonnet	ASTM A351 CF8M
3	Disc	ASTM A351 CF8M
4	Stem	316 SS
5	Packing	PTFE
6	Gland	316 SS
7	Gland Nut	ASTM A351 CF8M
8	Packing Washer	316 SS
9	Gasket	PTFE
10	Handwheel	ASTM A536
11	Handwheel Nut	304 SS
12	ID Tag	Aluminum

Dimensions and Weights

Valve Size	Weight (lbs)		Dimensions (inches)					
			A		B (open)		C	
1/2	1.0	0.9	2.01	2.1	5.1	3.8	2.6	2.1
3/4	1.3	1.5	2.20	2.3	5.8	4.6	2.6	2.6
1	1.7	2.5	2.48	2.8	6.6	5.3	3.0	2.8
1 1/2	3.4	3.2	3.01	3.6	9.4	7.3	3.6	3.6
2	5.2	7.0	3.41	3.9	11.0	8.4	4.0	4.1

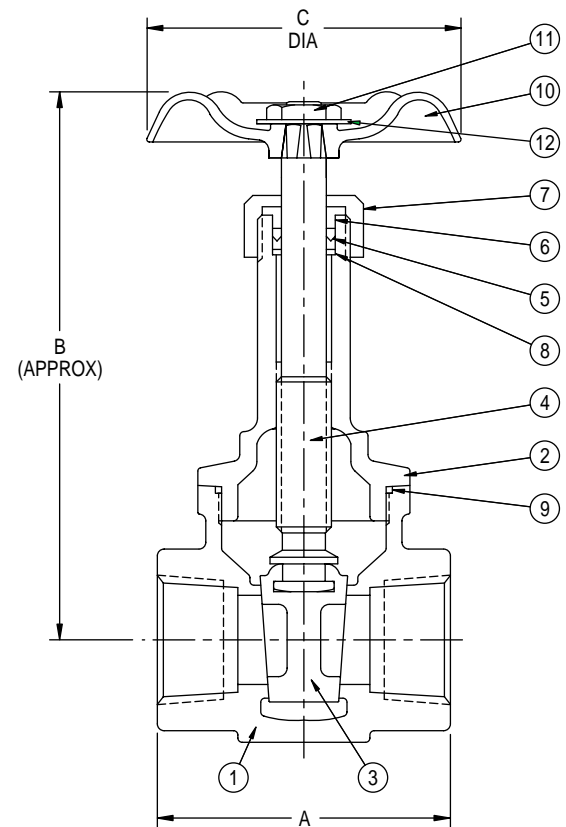

Fig. 90

Class 150 • O S & Y • Solid Wedge Disc

Figure 110

Threaded Ends

Figure 114

Socket Weld Ends

Size Range:

1/2 through 2 inches

Design Features:

- Bolted Bonnet
- Rising Stem
- Integral Seat
- Retained Gasket
- MSS-SP-42
- API 603 (except for end connections)

Industry Standards

Pipe Threads	ASME B1.20.1
Wall Section	ASME B16.34
Socket Weld Ends	ASME B16.11
End-to-End	Manufacturer's Standard
Pressure-Temp Rating	ASME B16.34
Testing	API 598

Materials of Construction

1	Body	ASTM A351 CF3M
2	Bonnet	ASTM A351 CF8M
3	Disc	ASTM A351 CF8M
4	Stem	ASTM A276 T316
5	Handwheel	ASTM A536
6	Gasket	PTFE
7	Gland Flange	ASTM A351 CF8
8	Gland	ASTM A276 T304
9	Packing	PTFE
10	Stem Nut	ASTM A536
11	Handwheel Nut	ASTM A276 T304
12	Bonnet Bolt Nut	ASTM A194 GR 8
13	Bonnet Bolt	ASTM A193 GR B8
14	Eyebolt Pin	ASTM A276 T304
15	Eyebolt	ASTM A193 GR B8
16	Eyebolt Nut	ASTM A194 GR 8
17	ID Tag	Aluminum
18	Washer	ASTM A536
19	Grease Fitting	304 SS
20	Set Screw	Steel

Dimensions and Weights

Valve Size	Weight (lbs)	Dimensions (inches)			
		A	B (open)	C	D*
1/2	6.8	2.76	8.1	3.9	.38
3/4	7.2	3.15	8.5	3.9	.50
1	9.8	3.54	9.1	3.9	.50
1 1/2	14.9	4.13	11.0	5.5	.50
2	20.1	4.72	12.6	6.3	.62

*For Figure 114 only - Socket weld depth

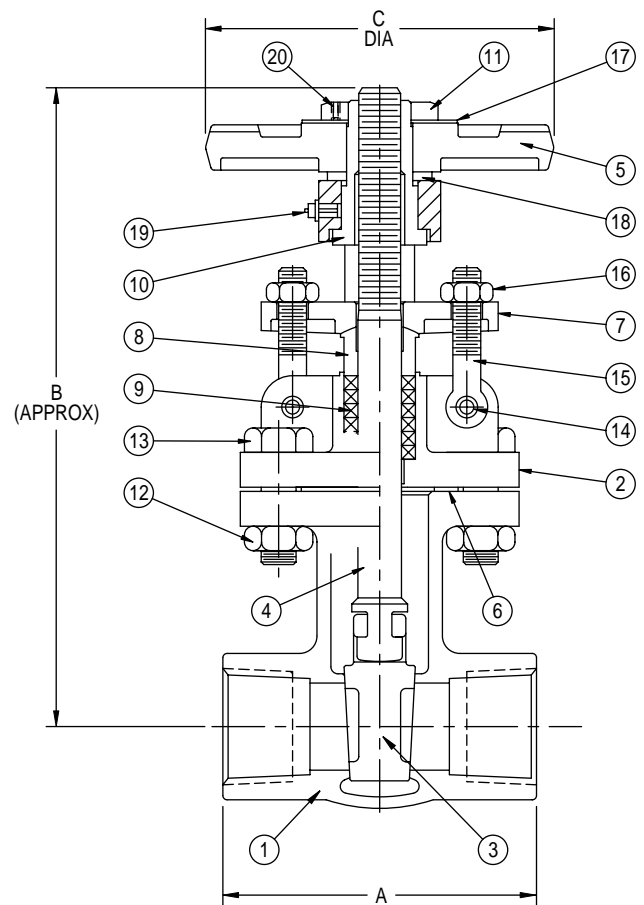

Fig. 110

Stainless Steel Gate Valves

Class 150 • O S & Y • Solid or Flexible Wedge Disc

Figure 117

Raised Face, Flanged Ends, Solid Wedge Disc

Figure 117F

Raised Face, Flanged Ends, Flexible Wedge Disc

Size Range:

1/2 through 24 inches

Design Features:

- Bolted Bonnet
- Rising Stem
- Integral Seat
- Retained Gasket
- MSS SP-42
- API 603

Industry Standards

End Flanges	ASME B16.5
Wall Section	ASME B16.34
Face-to-Face	ASME B16.10
Pressure-Temp Ratings	ASME B16.34
Design	API 603
Testing	API 598

Materials of Construction

1	Body	ASTM A351 CF8M
2	Bonnet	ASTM A351 CF8M
3	Disc	ASTM A351 CF8M
4	Stem	ASTM A276 T316
5	Handwheel	ASTM A536
6	Gasket	PTFE
7	Gland Flange	ASTM A351 CF8
8	Gland	ASTM A276 T304
9	Packing	PTFE
10	Stem Nut	ASTM A536
11	Handwheel Nut	ASTM A276 T304
12	Bonnet Bolt Nut	ASTM A194 GR 8
13	Bonnet Bolt	ASTM A193 GR B8
14	Eyebolt Pin	ASTM A276 T304
15	Eyebolt	ASTM A193 GR B8
16	Eyebolt Nut	ASTM A194 GR 8
17	ID Tag	Aluminum
18	Washer	ASTM A536
19	Grease Fitting	304 SS
20	Set Screw	Steel

Dimensions and Weights

Valve Size	Weight (lbs)	Dimensions (inches)		
		A	B (open)	C
1/2	7.4	4.25	8.1	3.9
3/4	8.3	4.63	8.5	3.9
1	10.0	5.00	9.1	3.9
1 1/2	18.0	6.50	11.0	5.5
2	27.0	7.00	12.6	6.3
2 1/2	37.5	7.50	15.1	6.3
3	46.3	8.00	16.7	7.9
4	75.0	9.00	20.9	9.8
6	128.0	10.50	28.7	12.4
8	216.1	11.50	36.9	14.0
10	291.1	13.00	43.9	14.0
12	436.6	14.00	51.9	15.7
14	703.4	15.00	58.5	17.7
16	1018.7	16.00	66.9	19.7
18	1190.7	17.00	74.8	22.0
20	1631.7	18.00	82.5	28.0
24	2434.3	20.00	97.4	31.5

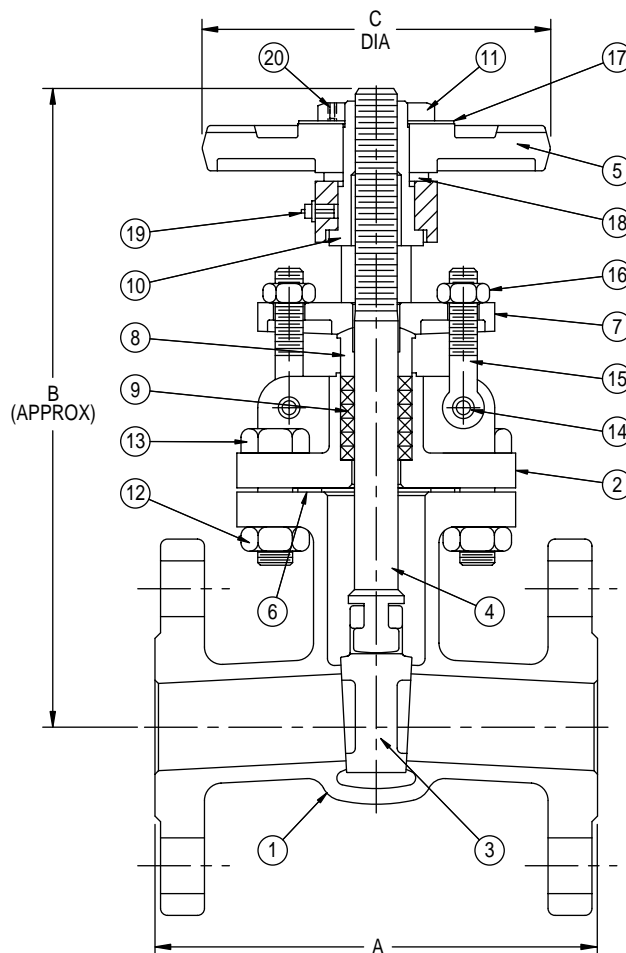

Fig. 117

Class 300 • O S & Y • Solid Wedge Disc

Figure 2110

Threaded Ends

Figure 2114

Socket Weld Ends

Size Range:

1/2 through 2 inches

Design Features:

- Bolted Bonnet
- Retained Gasket
- Rising Stem
- Integral Seat
- MSS-SP-42
- ASME B16.34

Industry Standards

Pipe Threads	ASME B1.20.1
Wall Section	ASME B16.34
Socket Weld Ends	ASME B16.11
End-to-End	Manufacturer's Standard
Pressure-Temp. Rating	ASME B16.34
Testing	API 598

Materials of Construction

1	Body	ASTM A351 CF3M
2	Bonnet	ASTM A351 CF8M
3	Disc	ASTM A351 CF8M
4	Stem	ASTM A276 T316
5	Handwheel	ASTM A536
6	Gasket	PTFE
7	Gland Flange	ASTM A351 CF8
8	Gland	ASTM A276 T304
9	Packing	PTFE
10	Stem Nut	ASTM A536
11	Handwheel Nut	ASTM A276 T304
12	Bonnet Bolt Nut	ASTM A194 GR 8
13	Bonnet Bolt	ASTM A193 GR B8
14	Eyebolt Pin	ASTM A276 T304
15	Eyebolt	ASTM A193 GR B8
16	Eyebolt Nut	ASTM A194 GR 8
17	ID Tag	Aluminum
18	Washer	ASTM A536
19	Grease Fitting	304 SS
20	Set Screw	Steel

Dimensions and Weights

Valve Size	Weight (lbs)	Dimensions (inches)			
		A	B (open)	C	D*
1/2	6.8	3.23	8.1	3.9	.38
3/4	7.0	3.23	8.1	3.9	.50
1	10.7	4.13	9.9	5.4	.50
1 1/2	19.5	4.92	12.0	7.9	.50
2	23.5	5.31	13.4	7.9	.62

*For Figure 2114 only - Socket weld depth

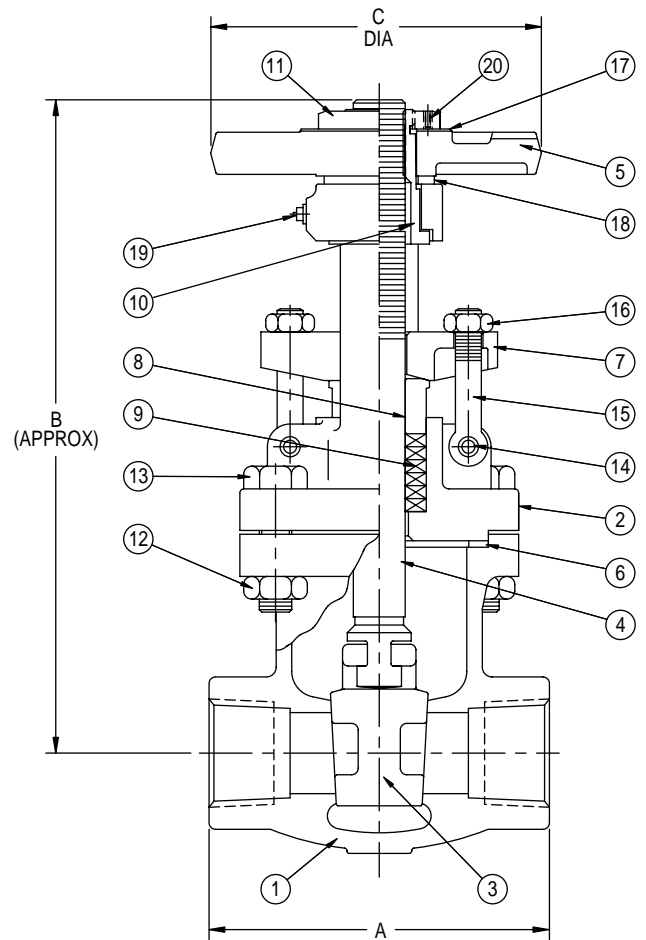

Fig. 2110

Stainless Steel Gate Valves

FIGURES
2117 • 2117F

Class 300 • O S & Y • Solid or Flexible Wedge Disc

Figure 2117

Raised Face, Flanged Ends, Solid Wedge Disc

Figure 2117F

Raised Face, Flanged Ends, Flexible Wedge Disc

Size Range:

1/2 through 24 inches

Design Features:

- Bolted Bonnet
- Retained Gasket
- Rising Stem
- Integral Seat
- MSS-SP-42
- ASME B16.34

Industry Standards

End Flanges	ASME B16.5
Wall Section	ASME B16.34
Face-to-Face	ASME B16.10
Pressure-Temp. Ratings	ASME B16.34
Testing	API 598

Materials of Construction

1	Body	ASTM A351 CF8M
2	Bonnet	ASTM A351 CF8M
3	Disc	ASTM A351 CF8M
4	Stem	ASTM A276 T316
5	Handwheel	ASTM A536
6	Gasket	PTFE
7	Gland Flange	ASTM A351 CF8
8	Gland	ASTM A276 T304
9	Packing	PTFE
10	Stem Nut	ASTM A536
11	Handwheel Nut	ASTM A276 T304
12	Bonnet Bolt Nut	ASTM A194 GR 8
13	Bonnet Bolt	ASTM A193 GR B8
14	Eyebolt Pin	ASTM A276 T304
15	Eyebolt	ASTM A193 GR B8
16	Eyebolt Nut	ASTM A194 GR 8
17	ID Tag	Aluminum
18	Washer	ASTM A536
19	Grease Fitting	304 SS
20	Set Screw	Steel

Dimensions and Weights

Valve Size	Weight (lbs)	Dimensions (inches)		
		A	B (open)	C
1/2	--	5.50	8.1	3.9
3/4	--	6.00	8.1	3.9
1	--	6.50	9.9	5.4
1 1/2	--	7.50	12.0	7.9
2	--	8.50	13.4	7.9
2 1/2	68.4	9.50	17.0	7.9
3	90.4	11.12	19.3	8.8
4	119.1	12.00	23.1	9.8
6	251.4	15.88	31.6	14.0
8	478.5	16.50	39.4	15.7
10	557.9	18.00	47.9	17.7
12	917.3	19.75	55.8	19.7
14	957.0	30.00	59.8	22.0
16	1206.1	33.00	66.7	24.8
18	1764.0	36.00	75.2	28.0
20	3281.0	39.00	83.4	31.5
24	4956.8	45.00	98.1	35.4

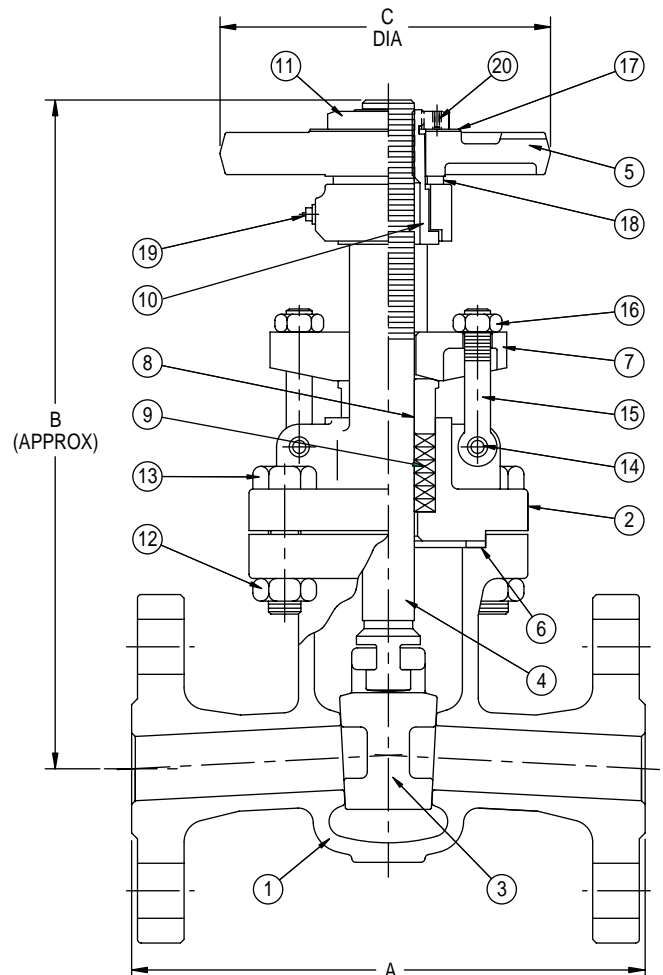

Fig. 2117



Class 600 • O S & Y • Solid Wedge Disc

Figure 4210

Threaded Ends

Figure 4214

Socket Weld Ends

Size Range:

1/2 through 2 inches

Design Features:

- Bolted Bonnet
- Retained Gasket
- Rising Stem
- Integral Seat
- ASME B16.34

Industry Standards

Pipe Threads	ASME B1.20.1
Wall Section	ASME B16.34
Socket Weld Ends	ASME B16.11
End-to-End	Manufacturer's Standards
Pressure-Temp Rating	ASME B16.34
Testing	API 598

Materials of Construction

1	Body	ASTM A351 CF3M
2	Bonnet	ASTM A351 CF8M
3	Disc	ASTM A351 CF8M
4	Stem	ASTM A351 CF8M
5	Handwheel	ASTM A536
6	Gasket	PTFE
7	Gland Flange	ASTM A351 CF8
8	Gland	ASTM A276 T304
9	Packing	PTFE
10	Stem Nut	ASTM A536
11	Handwheel Nut	ASTM A276 T304
12	Bonnet Bolt Nut	ASTM A194 GR 8
13	Bonnet Bolt	ASTM A193 GR B8
14	Eyebolt Pin	ASTM A276 T304
15	Eyebolt	ASTM A193 GR B8
16	Eyebolt Nut	ASTM A194 GR 8
17	ID Tag	Aluminum
18	Washer	ASTM A536
19	Grease Fitting	304 SS
20	Set Screw	Steel

Dimensions and Weights

Valve Size	Weight (lbs)	Dimensions (inches)			
		A	B (open)	C	D*
1/2	6.8	3.23	8.1	3.9	.38
3/4	7.0	3.23	8.1	3.9	.50
1	10.7	4.13	9.9	5.4	.50
1 1/2	19.5	4.92	12.0	7.9	.50
2	23.5	5.31	13.4	7.9	.62

*For Figure 4214 only - Socket weld depth

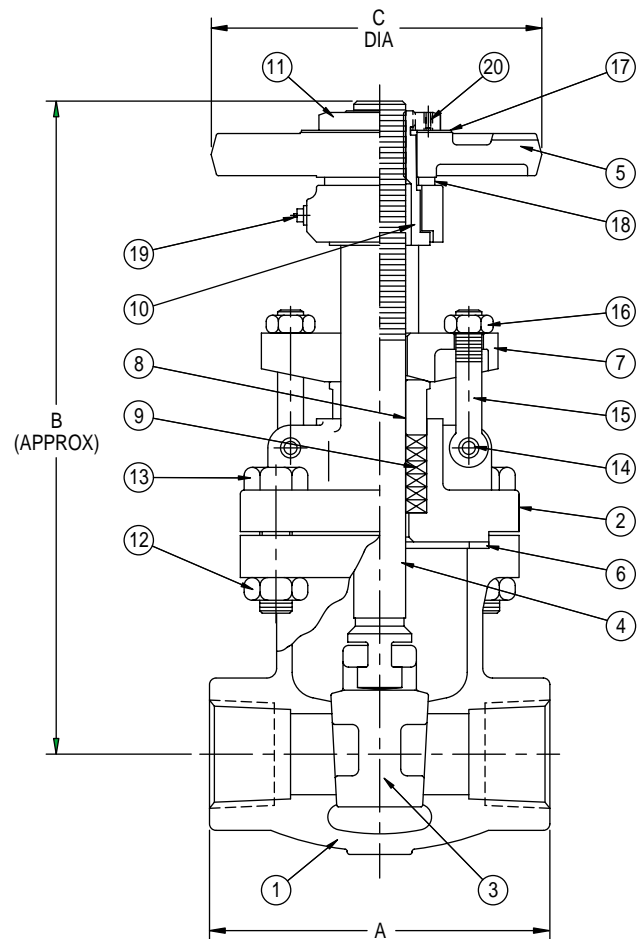

Fig. 4210

Stainless Steel Gate Valves

FIGURES
4217 • 4117F

Class 600 • O S & Y • Solid or Flexible Wedge Disc

Figure 4217

1/2 to 2 inches, Raised Face, Flanged Ends

Figure 4117F

2 1/2 to 24 inches, Raised Face, Flanged Ends

Size Range:

1/2 through 24 inches

Design Features:

- Bolted Bonnet
- Inside Screw
- Rising Stem
- Integral Seat
- Tested to API 598
- ASME B16.34

Industry Standards

End Flanges	ASME B16.5
Wall Section	ASME B16.34
Face-to-Face	ASME B16.10
Pressure-Temp. Ratings	ASME B16.34
Testing	API 598

Materials of Construction

1	Body	ASTM A351 CF8M
2	Bonnet	ASTM A351 CF8M
3	Disc	ASTM A351 CF8M
4	Stem	ASTM A276 T316
5	Handwheel	ASTM A536
6	Gasket	PTFE
7	Gland Flange	ASTM A351 CF8
8	Gland	ASTM A276 T304
9	Packing	PTFE
10	Stem Nut	ASTM A536
11	Handwheel Nut	ASTM A276 T304
12	Bonnet Bolt Nut	ASTM A194 GR 8
13	Bonnet Bolt	ASTM A193 GR B8
14	Eyebolt Pin	ASTM A276 T304
15	Eyebolt	ASTM A193 GR B8
16	Eyebolt Nut	ASTM A194 GR 8
17	ID Tag	Aluminum
18	Washer	ASTM A536
19	Grease Fitting	304 SS
20	Set Screw	Steel

Dimensions and Weights

Valve Size	Weight (lbs)	Dimensions (inches)		
		A	B (open)	C
1/2	---	6.50	8.1	3.9
3/4	---	7.50	8.1	3.9
1	---	8.50	9.9	5.4
1 1/2	---	9.50	12.0	7.9
2	---	11.50	13.4	7.9
2 1/2	111.8	13.00	18.0	8.8
3	145.9	14.00	20.1	9.8
4	277.1	17.00	25.0	14.0
6	534.8	22.00	37.7	17.7
8	938.4	26.00	42.4	19.7
10	1390.5	31.00	48.9	24.8
12	1993.4	33.00	56.7	28.0
14	2669.3	35.00	64.1	31.5
16	3121.4	39.00	71.1	35.4
18	4915.5	43.00	78.1	35.4
20	6223.4	47.00	89.9	43.0
24	8693.3	55.00	107.0	43.0

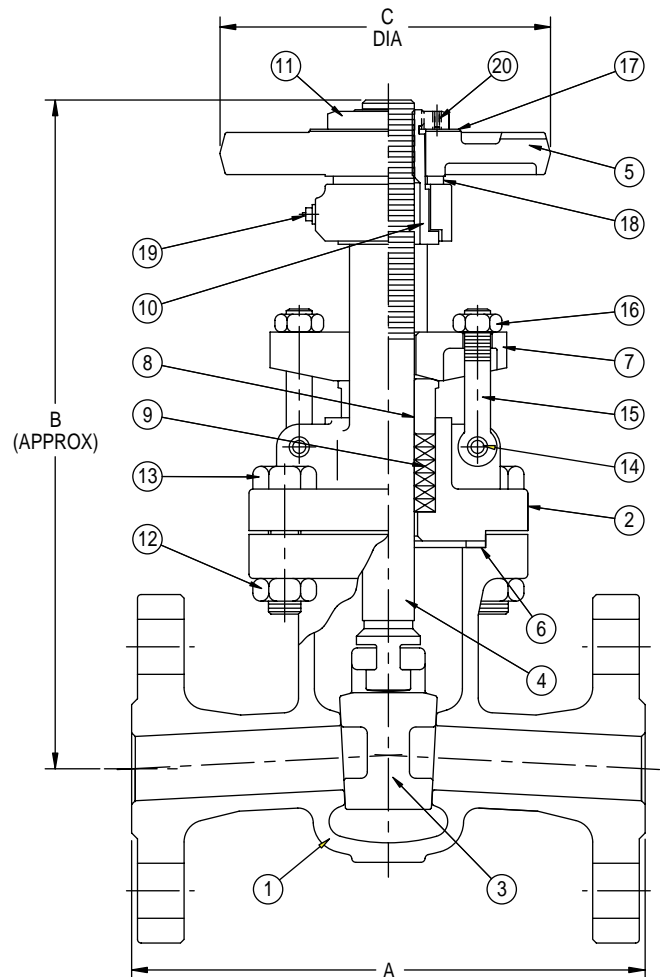

Fig. 4217



FIGURE 40

Stainless Steel Globe Valves

200 CWP • Threaded Bonnet • Plug Type Disc

Figure 40
Threaded Ends

Size Range:
1/2 through 2 inches

- Design Features:**
- Threaded Bonnet
 - Inside Screw
 - Rising Stem
 - Integral Seat

Pressure Temperature Ratings:
200 psi @ -20° to 100°F
135 psi @ 500°F max.

Industry Standards

Threaded Ends	ASME B1.20.1
End-to-End	Manufacturer's Standard

Materials of Construction

1	Body	ASTM A351 CF8M
2	Bonnet	ASTM A351 CF8M
3	Disc	316 SS
4	Stem	316 SS
5	Disc Nut	316 SS
6	Disc Washer	316 SS
7	Packing	PTFE
8	Gland	316 SS
9	Gland Nut	316 SS
10	Packing Washer	316 SS
11	Gasket	PTFE
12	Handwheel	Ductile Iron
13	Handwheel Nut	304 SS
14	ID Tag	304 SS

Dimensions and Weights

Valve Size	Weight (lbs)	Dimensions (inches)		
		A	B (open)	C
1/2	1.0	2.76	4.0	2.6
3/4	1.4	3.15	4.0	2.6
1	1.8	3.54	4.2	3.0
1 1/2	3.3	4.72	5.4	3.4
2	4.9	5.51	5.8	4.0

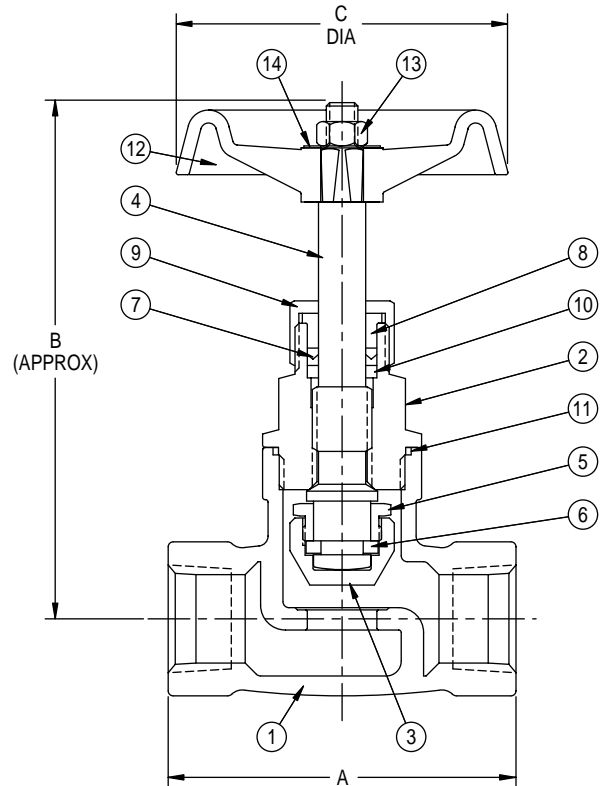

Fig. 40

Stainless Steel Globe Valves

Class 150 • O S & Y • Plug Type Disc

Figure 310

Threaded Ends

Figure 314

Socket Weld Ends

Size Range:

1/2 through 2 inches

Design Features:

- Bolted Bonnet
- Retained Gasket
- Rising Stem
- Integral Seat
- MSS-SP-42
- ASME B16.34

Industry Standards

Pipe Threads	ASME B1.20.1
Wall Section	ASME B16.34
Socket Weld Ends	ASME B16.11
End-to-End	Manufacturer's Standard
Pressure-Temp. Ratings	ASME B16.34
Testing	API 598

Materials of Construction

1	Body	ASTM A351 CF3M
2	Bonnet	ASTM A351 CF8M
3	Disc	ASTM A351 CF8M
4	Stem	ASTM A276 T316
5	Disc Nut	ASTM A276 T316
6	Handwheel	ASTM A536
7	Gasket	PTFE
8	Gland Flange	ASTM A351 CF8
9	Gland	ASTM A276 T304
10	Packing	PTFE
11	Stem Nut	ASTM A536
12	Handwheel Nut	ASTM A194 GR 8
13	Bonnet Bolt Nut	ASTM A194 GR 8
14	Bonnet Bolt	ASTM A193 GR B8
15	Eyebolt Pin	ASTM A276 T304
16	Eyebolt	ASTM A193 GR B8
17	Eyebolt Nut	ASTM A194 GR 8
18	ID Tag	Aluminum
19	Washer	ASTM A276 T304

Dimensions and Weights

Valve Size	Weight (lbs)	Dimensions (inches)			
		A	B (open)	C	D*
1/2	6.6	3.74	7.1	3.9	.38
3/4	6.9	4.53	7.3	3.9	.50
1	8.7	4.92	7.9	3.9	.50
1 1/2	12.6	5.52	9.2	5.5	.50
2	17.3	6.50	10.2	6.3	.31

* For Figure 314 only - socket weld depth

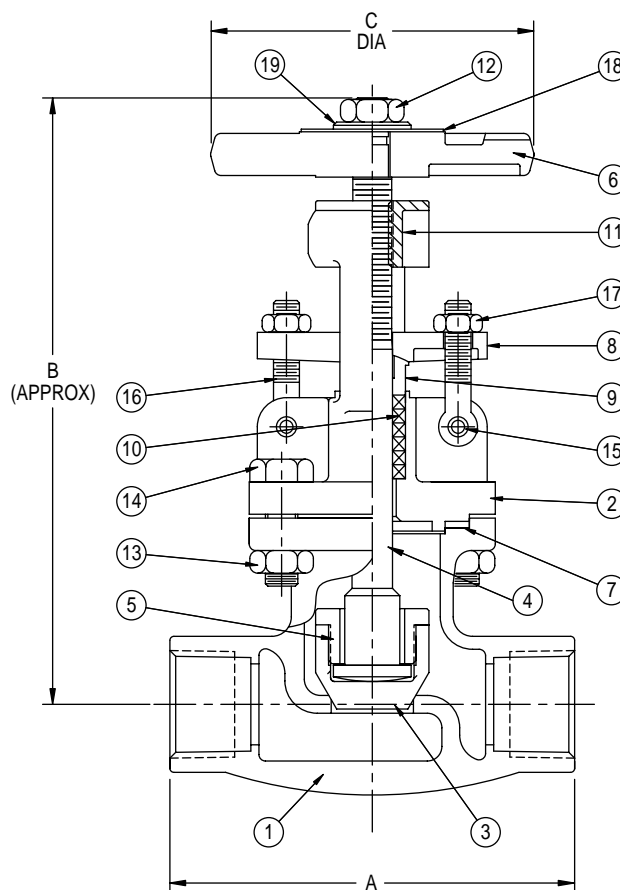

Fig. 310

FIGURE 317

Stainless Steel Globe Valves

Class 150 • O S & Y • Plug Type Disc

Figure 317

Raised Face, Flanged Ends

Size Range:

1/2 through 12 inches

Design Features:

- Bolted Bonnet
- Rising Stem
- Retained Gasket
- Integral Seat
- Disc Guide Below Seat
- MSS-SP-42
- ASME B16.34

Industry Standards

End Flanges	ASME B16.5
Wall Section	ASME B16.34
Face-to-Face	ASME B16.10
Pressure-Temp. Ratings	ASME B16.34
Testing	API 598

Materials of Construction

1	Body	ASTM A351 CF8M
2	Bonnet	ASTM A351 CF8M
3	Disc	ASTM A351 CF8M
4	Stem	ASTM A276 T316
5	Disc Nut	ASTM A276 T316
6	Handwheel	ASTM A536
7	Gasket	PTFE
8	Gland Flange	ASTM A351 CF8
9	Gland	ASTM A276 T304
10	Packing	PTFE
11	Stem Nut	ASTM A536
12	Handwheel Nut	ASTM A194 GR 8
13	Bonnet Bolt Nut	ASTM A194 GR 8
14	Bonnet Bolt	ASTM A193 GR B8
15	Eyebolt Pin	ASTM A276 T304
16	Eyebolt	ASTM A193 GR 8
17	Eyebolt Nut	ASTM A194 GR 8
18	ID Tag	Aluminum
19	Washer	ASTM A276 T304

Dimensions and Weights

Valve Size	Weight (lbs)	Dimensions (inches)		
		A	B (open)	C
1/2	7.6	4.25	7.1	3.9
3/4	8.9	4.63	7.3	3.9
1	11.6	5.00	7.9	3.9
1 1/2	16.4	6.50	9.2	5.5
2	25.2	8.00	10.2	6.3
2 1/2	46.3	8.50	11.1	7.9
3	61.7	9.50	13.5	8.8
4	97.0	11.50	14.8	11.0
6	198.5	16.00	16.9	14.0
8	383.7	19.50	22.0	14.0
10	546.8	24.50	29.7	15.7
12	848.9	27.50	32.5	15.7

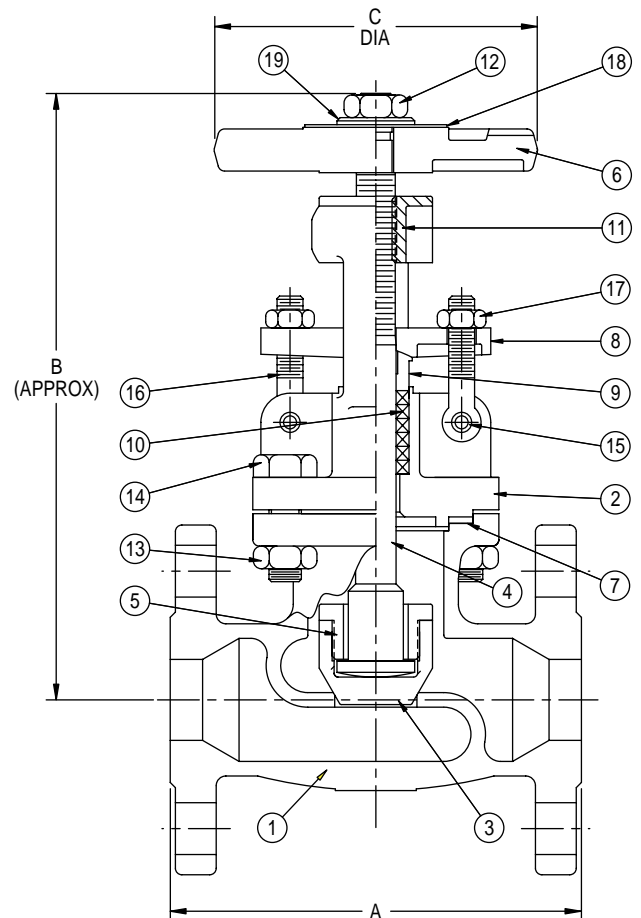

Fig. 317

Stainless Steel Globe Valves

FIGURES
2310 • 2314

Class 300 • O S & Y • Plug Type Disc

Figure 2310

Threaded Ends

Figure 2314

Socket Weld Ends

Size Range:

1/2 through 2 inches

Design Features:

- Bolted Bonnet
- Rising Stem
- Retained Gasket
- Integral Seat
- MSS-SP-42

Industry Standards

Pipe Threads	ASME B1.20.1
Wall Section	ASME B16.34
Face-to-Face	Manufacturer's Standard
Pressure-Temp. Ratings	ASME B16.34
Socket Weld Ends	ASME B16.11
Testing	API 598

Materials of Construction

1	Body	ASTM A351 CF3M
2	Bonnet	ASTM A351 CF8M
3	Disc	ASTM A351 CF8M
4	Stem	ASTM A276 T316
5	Handwheel	ASTM A536
6	Gasket	PTFE
7	Gland Flange	ASTM A351 CF8
8	Gland	ASTM A276 T304
9	Packing	PTFE
10	Stem Nut	ASTM A536
11	Handwheel Nut	ASTM A193 GR 8
12	Bonnet Bolt Nut	ASTM A194 GR 8
13	Bonnet Bolt	ASTM A193 GR B8
14	Eyebolt Pin	ASTM A276 T304
15	Eyebolt	ASTM A193 GR B8
16	Eyebolt Nut	ASTM A194 GR 8
17	ID Tag	Aluminum
18	Washer	304 SS
19	Stem Ring	ASTM A276 T316

Dimensions and Weights

Valve Size	Weight (lbs)	Dimensions (inches)			
		A	B (open)	C	D*
1/2	7.0	3.23	7.8	3.9	.38
3/4	7.0	3.23	7.8	3.9	.50
1	10.3	4.13	9.0	3.9	.50
1 1/2	18.2	4.92	10.7	5.5	.50
2	22.6	5.91	11.3	6.3	.62

* For Figure 2314 only - socket weld depth

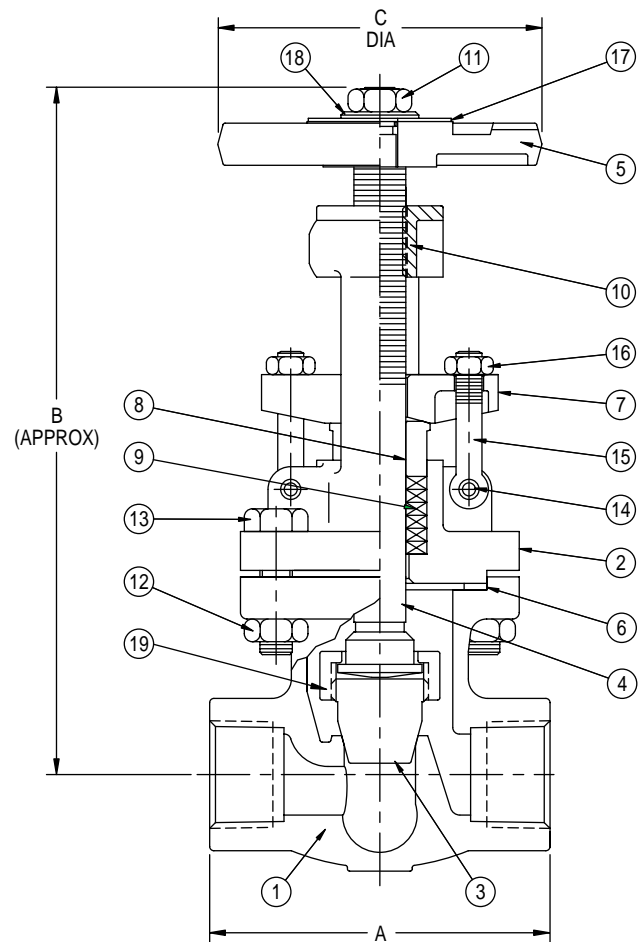

Fig. 2310

FIGURE 2317

Stainless Steel Globe Valves

Class 300 • O S & Y • Plug Type Disc

Figure 2317

Raised Face, Flanged Ends

Size Range:

1/2 through 8 inches

Design Features:

- Bolted Bonnet
- Retained Gasket
- Rising Stem, Rising Handwheel
- Integral Seat
- MSS-SP-42
- ASME B16.34

Industry Standards

End Flanges	ASME B16.5
Wall Section	ASME B16.34
Face-to-Face	ASME B16.10
Pressure-Temp. Ratings	ASME B16.34
Testing	API 598

Materials of Construction

1	Body	ASTM A351 CF8M
2	Bonnet	ASTM A351 CF8M
3	Disc	ASTM A351 CF8M
4	Stem	ASTM A276 T316
5	Handwheel	ASTM A536
6	Gasket	PTFE
7	Gland Flange	ASTM A351 CF8
8	Gland	ASTM A276 T304
9	Packing	PTFE
10	Stem Nut	ASTM A536
11	Handwheel Nut	ASTM A193 GR 8
12	Bonnet Bolt Nut	ASTM A194 GR 8
13	Bonnet Bolt	ASTM A193 GR B8
14	Eyebolt Pin	ASTM A276 T304
15	Eyebolt	ASTM A193 GR B8
16	Eyebolt Nut	ASTM A194 GR 8
17	ID Tag	Aluminum
18	Washer	304 SS
19	Stem Ring	ASTM A276 T316

Dimensions and Weights

Valve Size	Weight (lbs)	Dimensions (inches)		
		A	B (open)	C
1/2	---	6.00	7.8	3.9
3/4	---	7.00	7.8	3.9
1	---	8.00	9.0	3.9
1 1/2	---	9.00	10.7	5.5
2	---	10.50	11.3	6.3
2 1/2	83.8	11.50	13.9	7.9
3	83.8	12.50	15.1	8.8
4	130.1	14.00	17.4	11.0
6	317.5	17.50	22.3	15.8
8	562.3	22.00	24.2	15.8

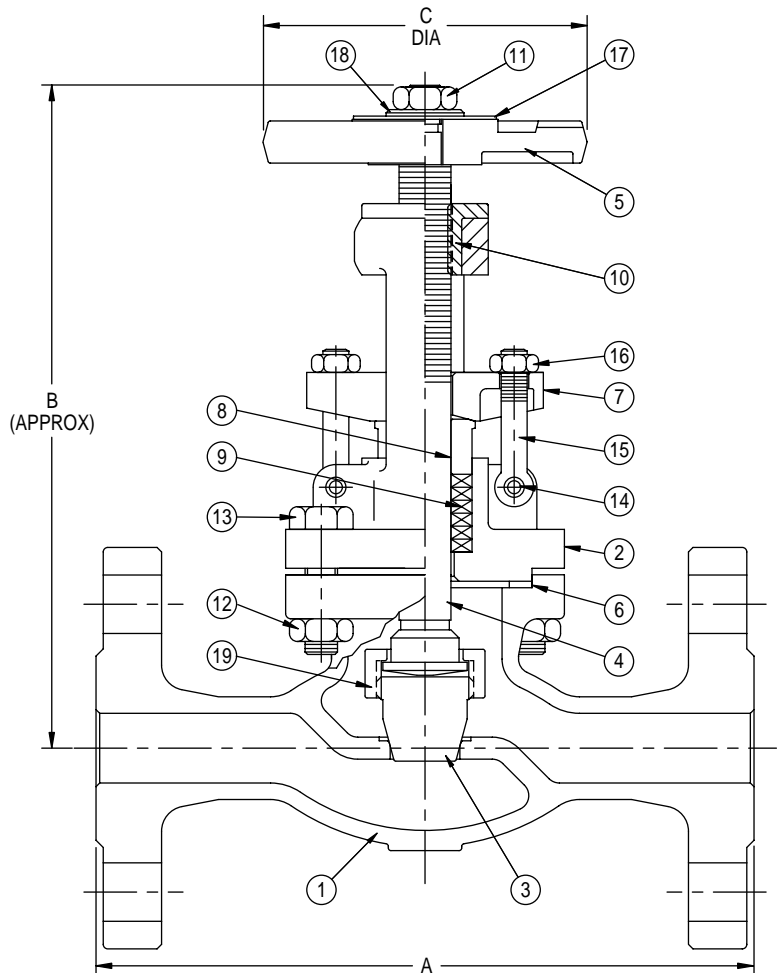

Fig. 2317

Stainless Steel Globe Valves

Class 600 • O S & Y • Plug Type Disc

Figure 4310

Threaded Ends

Figure 4314

Socket Weld Ends

Size Range:

1/2 through 2 inches

Design Features:

- Bolted Bonnet
- Rising Stem
- Retained Gasket
- Integral Seat
- MSS SP-42

Industry Standards

Pipe Threads	ASME B1.20.1
Wall Section	ASME B16.34
Face-to-Face	Manufacturer's Standard
Pressure-Temp. Ratings	ASME B16.34
Socket Weld Ends	ASME B16.11
Testing	API 598

Materials of Construction

1	Body	ASTM A351 CF3M
2	Bonnet	ASTM A351 CF8M
3	Disc	ASTM A351 CF8M
4	Stem	ASTM A276 T316
5	Handwheel	ASTM A536
6	Gasket	PTFE
7	Gland Flange	ASTM A351 CF8
8	Gland	ASTM A276 T304
9	Packing	PTFE
10	Stem Nut	ASTM A536
11	Handwheel Nut	ASTM A193 GR 8
12	Bonnet Bolt Nut	ASTM A194 GR 8
13	Bonnet Bolt	ASTM A193 GR B8
14	Eyebolt Pin	ASTM A276 T304
15	Eyebolt	ASTM A193 GR B8
16	Eyebolt Nut	ASTM A194 GR 8
17	ID Tag	Aluminum
18	Washer	304 SS
19	Stem Ring	ASTM A276 T316

Dimensions and Weights

Valve Size	Weight (lbs)	Dimensions (inches)			
		A	B (open)	C	D*
1/2	7.0	3.23	7.8	3.9	.38
3/4	7.0	3.23	7.8	3.9	.50
1	10.3	4.13	9.0	3.9	.50
1 1/2	18.2	4.92	10.7	5.5	.50
2	22.6	5.91	11.3	6.3	.62

* For Figure 2314 only - socket weld depth

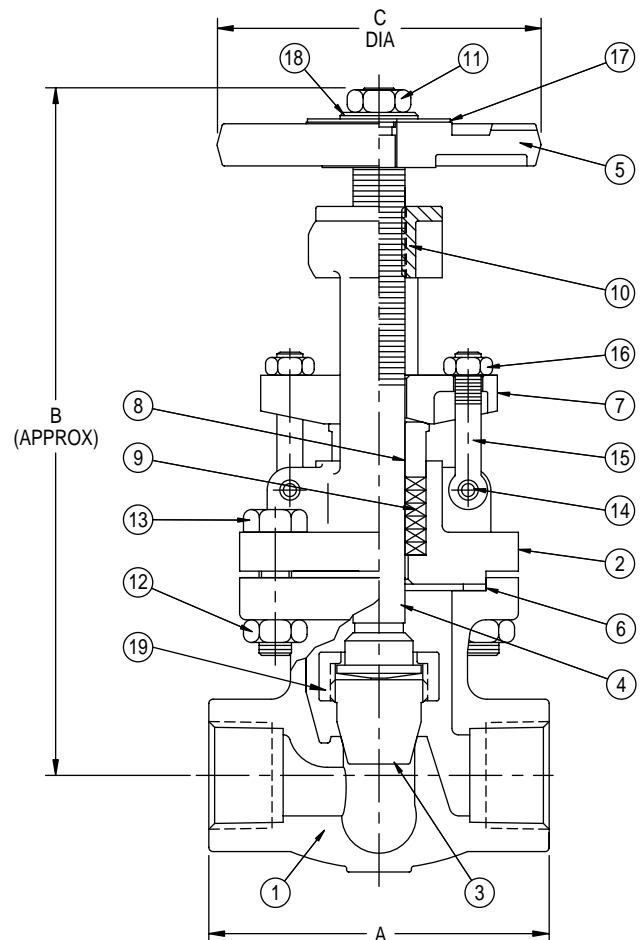

Fig. 4310

FIGURE 4317

Stainless Steel Globe Valves

Class 600 • O S & Y • Plug Type Disc

Figure 4317

Raised Face, Flanged Ends

Size Range:

1/2 through 6 inches

Design Features:

- Bolted Bonnet
- Retained Gasket
- Rising Stem, Rising Handwheel
- Integral Seat
- MSS SP-42
- ASME B16.34

Industry Standards

End Flanges	ASME B16.5
Wall Section	ASME B16.34
Face-to-Face	ASME B16.10
Pressure-Temp. Ratings	ASME B16.34
Testing	API 598

Materials of Construction

1	Body	ASTM A351 CF8M
2	Bonnet	ASTM A351 CF8M
3	Disc	ASTM A351 CF8M
4	Stem	ASTM A276 T316
5	Handwheel	ASTM A536
6	Gasket	PTFE
7	Gland Flange	ASTM A351 CF8
8	Gland	ASTM A276 T304
9	Packing	PTFE
10	Stem Nut	ASTM A536
11	Handwheel Nut	ASTM A193 GR 8
12	Bonnet Bolt Nut	ASTM A194 GR 8
13	Bonnet Bolt	ASTM A193 GR B8
14	Eyebolt Pin	ASTM A276 T304
15	Eyebolt	ASTM A193 GR B8
16	Eyebolt Nut	ASTM A194 GR 8
17	ID Tag	Aluminum
18	Washer	304 SS
19	Stem Ring	ASTM A276 T316

Dimensions and Weights

Valve Size	Weight (lbs)	Dimensions (inches)		
		A	B (open)	C
1/2	---	6.50	7.8	3.9
3/4	---	7.50	7.8	3.9
1	---	8.50	9.0	3.9
1 1/2	---	9.50	10.7	5.5
2	---	11.50	11.3	6.3
2 1/2	119.1	13.00	17.0	11.0
3	138.9	14.00	18.8	12.4
4	264.6	17.00	20.9	12.4
6	480.7	22.00	26.6	17.7

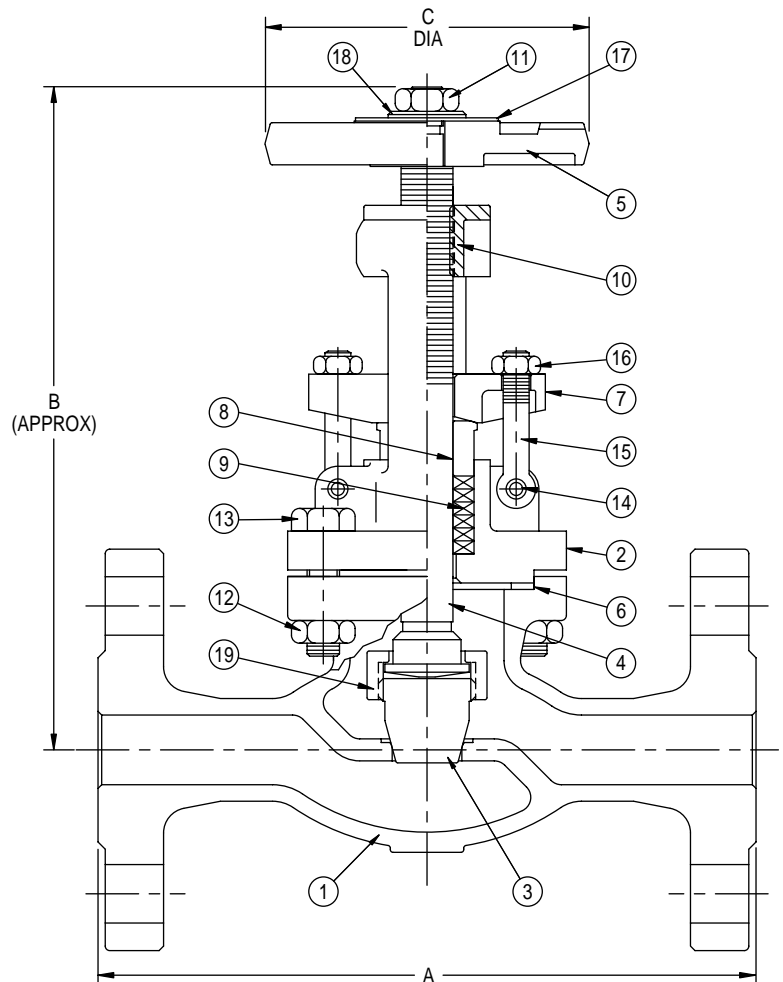

Fig. 4317

Stainless Steel Check Valves

200 CWP • Y-Pattern • Threaded Cap

Figure 49
Threaded Ends

Size Range:
1/2 through 2 inches

Design Features:

- Integral Seat
- Y Pattern

Pressure Temperature Ratings:

- 200 psi @ -20°F to 100°F
- 135 psi @ 500°F Max

Industry Standards

Pipe Threads	ASME B1.20.1
--------------	--------------

Materials of Construction

1	Body	ASTM A351 CF8M
2	Cap	ASTM A351 CF8M
3	Disc	ASTM A351 CF8M
4	Hinge Arm	ASTM A351 CF8M
5	Hinge Pin	316 SS
6	Disc Nut	316 SS
7	Disc Washer	316 SS
8	Plug	316 SS
9	Seal	PTFE
10	Gasket	PTFE

Dimensions and Weights

Valve Size	Weight (lbs)	Dimensions (inches)	
		A	B
1/2	0.7	2.56	1.8
3/4	1.1	3.15	2.0
1	1.5	3.54	2.4
1 1/2	3.1	4.72	3.2
2	4.6	5.51	3.7

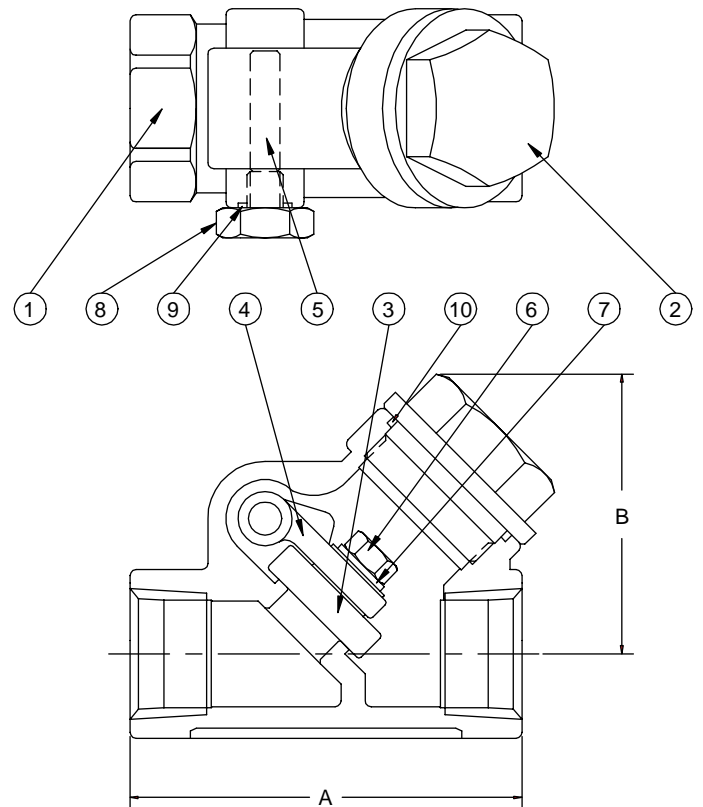

Fig. 49

Class 150 • Bolted Cover

Figure 370

Threaded Ends

Figure 374

Socket Weld Ends

Size Range:

1/2 through 2 inches

Design Features:

- Retained Gasket
- Integral Seat
- ASME B16.34

Industry Standards

Pipe Threads	ASME B2.1
Wall Section	ASME B16.34
Socket Weld Ends	ASME B16.11
End-to-End	Manufacturer's Standard
Pressure Temp. Ratings	ASME B16.34
Testing	API 598

Materials of Construction

1	Body	ASTM A351 CF3M
2	Cover	ASTM A351 CF8M
3	Disc	ASTM A351 CF8M
4	Hinge Arm	ASTM A351 CF8M
5	Hinge Pin	ASTM A276 T316
6	Disc Washer	ASTM A276 T304
7	Disc Nut	ASTM A194 GR 8
8	Plug	ASTM A276 T316
9	Gasket	PTFE
10	Plug Seal	PTFE
11	Cover Bolt	ASTM A193 GR B8
12	Cover Bolt Nut	ASTM A194 GR 8
13	ID Tag	ASTM A276 T304

Dimensions and Weights

Valve Size	Weight (lbs)	Dimensions (inches)		
		A	B	C*
1/2	3.5	3.35	2.4	.38
3/4	3.7	3.74	2.8	.50
1	5.5	4.53	3.1	.50
1 1/2	8.6	4.92	4.1	.50
2	10.3	5.91	4.6	.62

* For Figure 374 only - socket weld depth

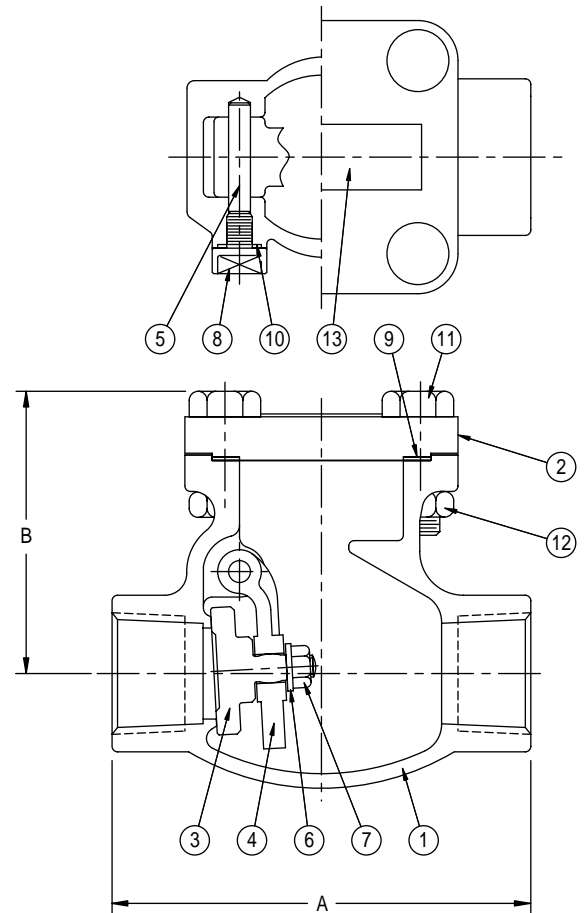

Fig. 370

Stainless Steel Check Valves

Class 150 • Bolted Cover

Figure 377

Raised Face, Flanged Ends

Size Range:

1/2 through 24 inches

Design Features:

- Retained Gasket
- Integral Seat
- MSS-SP-42
- ASME B16.34

Industry Standards

End Flanges	ASME B16.5
Wall Section	ASME B16.34
Face-to-Face	ASME B16.10
Pressure-Temp. Ratings	ASME B16.34
Testing	API 598

Materials of Construction

1	Body	ASTM A351 CF8M
2	Cover	ASTM A351 CF8M
3	Disc	ASTM A351 CF8M
4	Hinge Arm	ASTM A351 CF8M
5	Hinge Pin	ASTM A276 T316
6	Disc Washer	ASTM A276 T304
7	Disc Nut	ASTM A194 GR 8M
8	Plug	ASTM A276 T316
9	Gasket	PTFE
10	Plug Seal	PTFE
11	Cover Bolt	ASTM A193 GR B8
12	Cover Bolt Nut	ASTM A194 GR 8
13	ID Tag	ASTM A276 T304

Dimensions and Weights

Valve Size	Weight (lbs)	Dimensions (inches)	
		A	B
1/2	4.2	4.25	2.4
3/4	5.6	4.63	2.8
1	8.4	5.00	3.1
1 1/2	13.5	6.50	4.1
2	20.4	8.00	4.6
2 1/2	50.7	8.50	6.1
3	57.3	9.50	6.3
4	99.2	11.50	7.9
6	172.0	14.00	9.8
8	299.9	19.50	11.5
10	471.9	24.50	13.0
12	707.8	27.50	13.9
14	904.1	31.00	15.5
16	1133.4	34.00	16.5
18	1633.9	38.50	20.1
20	2070.5	38.50	21.7
24	2967.9	51.00	22.0

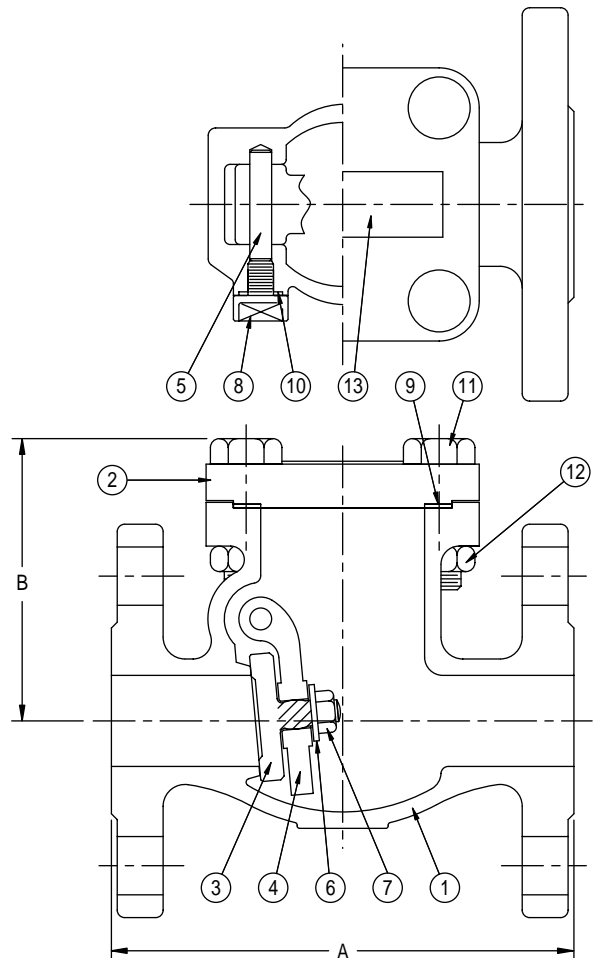

Fig. 377



Class 300 • Bolted Cover

Figure 2370

Threaded Ends

Figure 2374

Socket Weld Ends

Size Range:

1/2 through 2 inches

Design Features:

- Retained Gasket
- Integral Seat

Industry Standards

Pipe Threads	ASME B1.20.1
Wall Section	ASME B16.34
Socket Weld Ends	ASME B16.11
End-to-End	Manufacturer's Standard
Pressure Temp. Ratings	ASME B16.34
Testing	API 598

Materials of Construction

1	Body	ASTM A351 CF3M
2	Cover	ASTM A351 CF8M
3	Disc	ASTM A351 CF8M
4	Hinge Arm	ASTM A351 CF8M
5	Hinge Pin	ASTM A276 T316
6	Disc Washer	ASTM A276 T304
7	Disc Nut	ASTM A194 GR 8
8	Gasket	PTFE
9	Cover Bolt	ASTM A193 GR B8
10	Cover Bolt Nut	ASTM A194 GR 8
11	ID Tag	ASTM A276 T304

Dimensions and Weights

Valve Size	Weight (lbs)	Dimensions (inches)		
		A	B	C*
1/2	4.2	3.23	3.3	.38
3/4	4.2	3.23	3.3	.50
1	5.8	4.13	3.4	.50
1 1/2	10.1	4.92	3.9	.50
2	13.1	5.31	4.1	.62

* For Figure 2374 only - socket weld depth

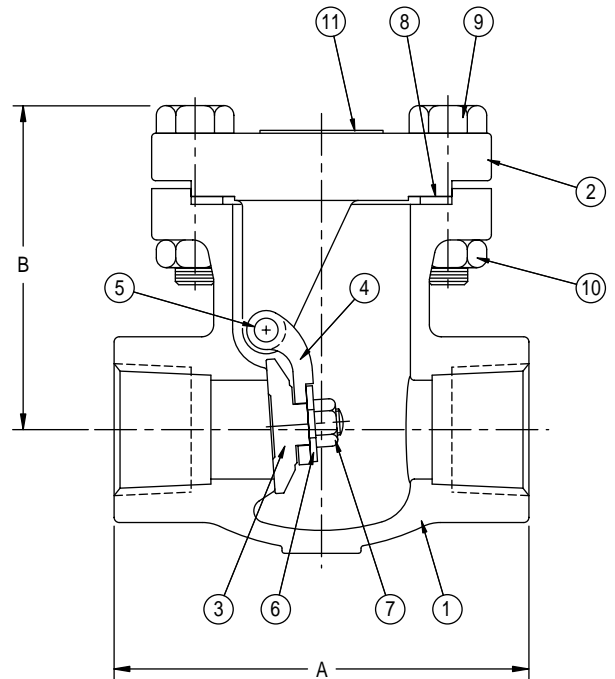

Fig. 2370

Stainless Steel Check Valves

Class 300 • Bolted Cover

Figure 2377
Raised Face, Flanged Ends

Size Range:
1/2 through 24 inches

- Design Features:**
- Retained Gasket
 - Integral Seat
 - MSS-SP-42

Industry Standards

End Flanges	ASME B16.5
Wall Section	ASME B16.34
Face-to-Face	ASME B16.10
Pressure-Temp. Ratings	ASME B16.34
Testing	API 598

Materials of Construction

1	Body	ASTM A351 CF8M
2	Cover	ASTM A351 CF8M
3	Disc	ASTM A351 CF8M
4	Hinge Arm	ASTM A351 CF8M
5	Hinge Pin	ASTM A276 T316
6	Disc Washer	ASTM A276 T304
7	Disc Nut	ASTM A194 GR 8
8	Gasket	PTFE
9	Cover Bolt	ASTM A193 GR B8
10	Cover Bolt Nut	ASTM A194 GR 8
11	ID Tag	ASTM A276 T304

Dimensions and Weights

Valve Size	Weight (lbs)	Dimensions (inches)	
		A	B
1/2	---	6.00	3.3
3/4	---	7.00	3.3
1	---	8.50	3.4
1 1/2	---	9.50	3.9
2	---	10.50	4.1
2 1/2	81.6	11.50	6.5
3	92.6	12.50	6.9
4	141.1	14.00	7.3
6	273.4	17.50	10.3
8	489.5	21.00	12.3
10	643.9	24.50	14.0
12	979.0	28.00	15.5
14	1420.0	33.00	20.1
16	1753.0	34.00	20.5
18	2319.7	38.50	22.5
20	2668.1	40.00	24.5
24	4224.8	53.00	28.0

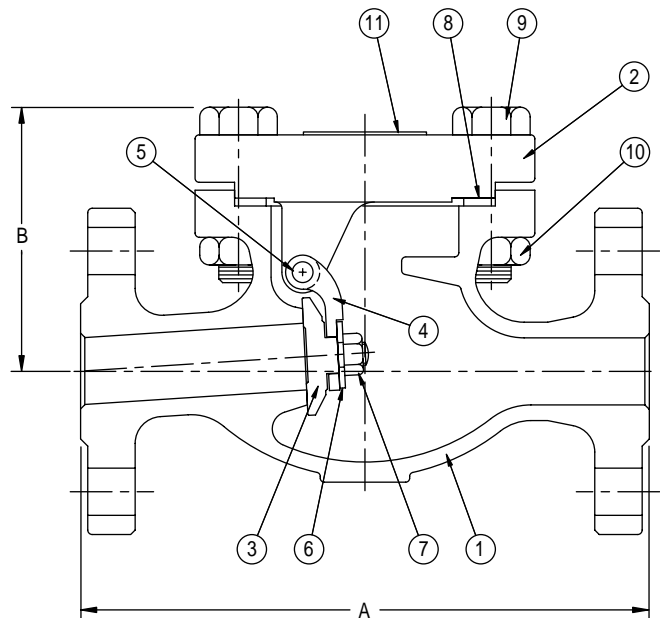

Fig. 2377

Class 600 • Bolted Cover

Figure 4370

Threaded Ends

Figure 4374

Socket Weld Ends

Size Range:

1/2 through 2 inches

Design Features:

- Retained Gasket
- Integral Seat

Industry Standards

Pipe Threads	ASME B1.20.1
Wall Section	ASME B16.34
Socket Weld Ends	ASME B16.11
End-to-End	Manufacturer's Standard
Pressure Temp. Ratings	ASME B16.34
Testing	API 598

Materials of Construction

1	Body	ASTM A351 CF3M
2	Cover	ASTM A351 CF8M
3	Disc	ASTM A351 CF8M
4	Hinge Arm	ASTM A351 CF8M
5	Hinge Pin	ASTM A276 T316
6	Disc Washer	ASTM A276 T304
7	Disc Nut	ASTM A194 GR 8
8	Gasket	PTFE
9	Cover Bolt	ASTM A193 GR B8
10	Cover Bolt Nut	ASTM A194 GR 8
11	ID Tag	ASTM A276 T304

Dimensions and Weights

Valve Size	Weight (lbs)	Dimensions (inches)		
		A	B	C*
1/2	4.2	3.23	3.3	.38
3/4	4.2	3.23	3.3	.50
1	5.8	4.13	3.4	.50
1 1/2	10.1	4.92	3.9	.50
2	13.1	5.31	4.1	.62

* For Figure 4374 only - socket weld depth

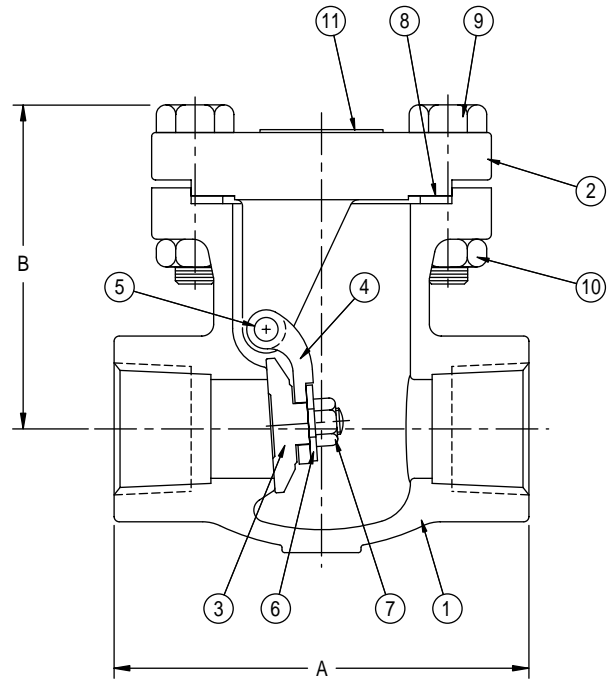

Fig. 4370

Stainless Steel Check Valves

Class 600 • Bolted Cover

Figure 4377
Raised Face, Flanged Ends

Size Range:
1/2 through 12 inches

- Design Features:**
- Retained Gasket
 - Integral Seat
 - MSS SP-42

Industry Standards

End Flanges	ASME B16.5
Wall Section	ASME B16.34
Face-to-Face	ASME B16.10
Pressure-Temp. Ratings	ASME B16.34
Testing	API 598

Materials of Construction

1	Body	ASTM A351 CF8M
2	Cover	ASTM A351 CF8M
3	Disc	ASTM A351 CF8M
4	Hinge Arm	ASTM A351 CF8M
5	Hinge Pin	ASTM A276 T316
6	Disc Washer	ASTM A276 T304
7	Disc Nut	ASTM A194 GR 8
8	Gasket	PTFE
9	Cover Bolt	ASTM A193 GR B8
10	Cover Bolt Nut	ASTM A194 GR 8
11	ID Tag	ASTM A276 T304

Dimensions and Weights

Valve Size	Weight (lbs)	Dimensions (inches)	
		A	B
1/2	---	6.50	3.3
3/4	---	7.50	3.3
1	---	8.50	3.4
1 1/2	---	9.50	3.9
2	---	11.50	4.1
2 1/2	108.0	13.00	7.9
3	123.5	14.00	8.3
4	227.1	17.00	10.1
6	449.8	22.00	13.0
8	754.1	26.00	14.3
10	1375.9	31.00	18.3
12	1711.1	33.00	19.1

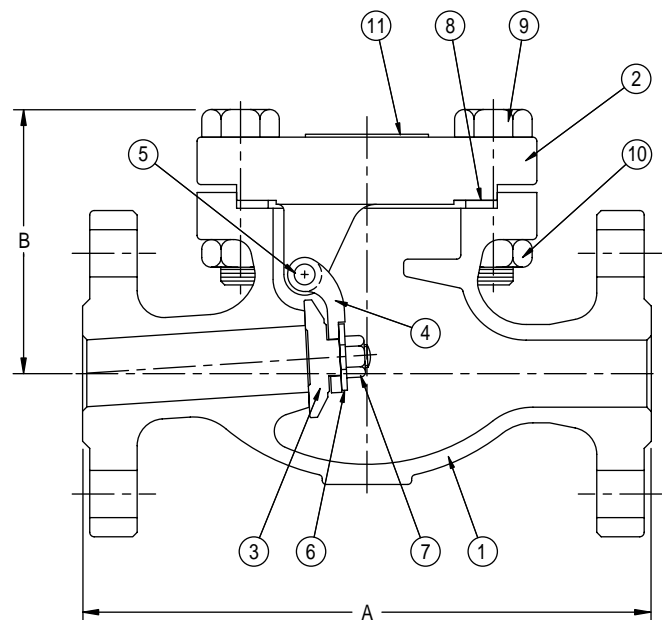

Fig. 4377

**FIGURE
9502**

Stainless Steel Ball Valves

2000 CWP • Two-Piece Body

Figure 9502

Threaded Ends

Size Range:

1/4 through 2 inches

Design Features:

- MSS SP-110
- Full Port
- Locking Handle
- Standard Mounting Pad
- Firesafe to API 607

Dimensions and Weights

Valve Size	Weight (lbs)	Dimensions (inches)						
		ØD	L	H	E	G1	G2	T
1/4	0.7	0.36	2.11	1.86	3.82	0.50	1.12	M5
3/8	0.7	0.36	2.11	1.86	3.82	0.50	1.12	M5
1/2	1.1	0.50	2.66	2.08	4.33	0.50	1.12	M5
3/4	1.8	0.75	2.97	2.23	4.33	0.87	1.37	M5
1	2.6	1.00	3.50	2.74	5.57	0.87	1.37	M5
1 1/4	3.3	1.25	3.96	2.94	5.57	0.93	1.50	M5
1 1/2	4.4	1.50	4.45	3.22	6.50	0.93	1.50	M6
2	9.5	2.00	5.18	4.42	10.04	0.93	1.50	M6

Materials of Construction

1	Body	CF8M
2	End Cap	CF8M
3	Gasket	Graphite
4	Body Seal	Teflon
5	Seats	RPTFE
6	Ball	CF8M
7	Stem	Type 316
8	Thrust Washer	RPTFE
9	Stem Packing	Graphite
10	Gland Nut	304SS
11	Stem Washer	304SS
12	Stem Nut	304SS
13	Handle	304SS
14	Locking Device	304SS

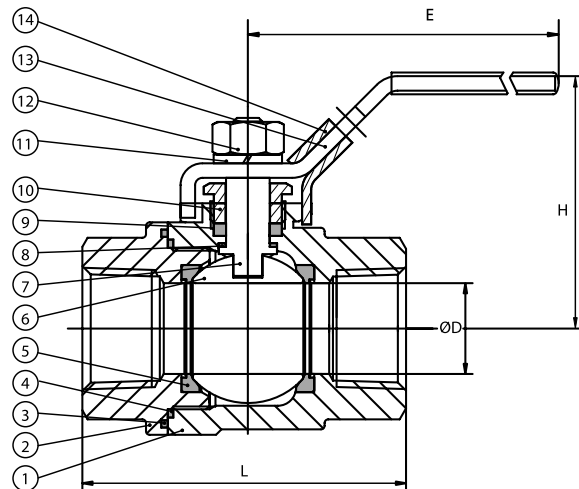
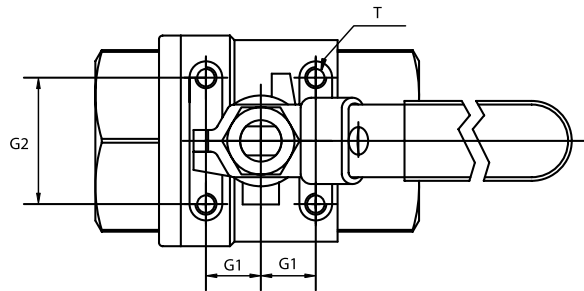

Fig. 9502

Materials of Construction

Composition, %					
Element	ASTM A351			ASTM A494	
	CF8M	CF3M	CN7M	M-35-1	CW-12MW
Carbon	0.08	0.03	0.07	0.35	0.12
Chromium	18.0 - 21.0	17.0 - 21.0	19.0 - 22.0	0.00	15.5 - 17.5
Columbium (Niobium)	0.00	0.00	0.00	0.50	0.00
Copper	0.00	0.00	3.0 - 4.0	26.0 - 33.0	0.00
Iron	0.00	0.00	0.00	3.50	4.5 - 7.5
Manganese	1.50	1.50	1.50	1.50	1.00
Molybdenum	2.0 - 3.0	2.0 - 3.0	2.0 - 3.0	0.00	16.0 - 18.0
Nickel	9.0 - 12.0	9.0 - 13.0	27.5 - 30.5	balance	balance
Phosphorus	0.04	0.04	0.04	0.03	0.04
Silicon	1.50	1.50	1.50	1.25	1.00
Sulfur	0.04	0.04	0.04	0.03	0.03
Tungsten	0.00	0.00	0.00	0.00	3.75 - 5.25
Vanadium	0.00	0.00	0.00	0.00	0.20 - 0.40

Assume all values are maximum, unless a range is given

	Tensile Requirements			Mechanical Properties	
Tensile Strength	70,000	70,000	62,000	65,000	72,000
Yield Strength	30,000	30,000	25,000	25,000	40,000
Elongation in 2 inches, %	30.0%	30.0%	35.0%	25.0%	4.0%

Pressure Temperature

Temp °F	ASTM A351 Gr. CF8M Working Pressure (psig)			ASTM A351 Gr. CF3M Working Pressure (psig)			ASTM A351 Gr. CN7M Working Pressure (psig)			ASTM A494 M-35-1 Working Pressure (psig)			ASTM A494 Gr. CW-12MW Working Pressure (psig)		
	CL. 150	CL. 300	CL. 600	CL. 150	CL. 300	CL. 600	CL. 150	CL. 300	CL. 600	CL. 150	CL. 300	CL. 600	CL. 150	CL. 300	CL. 600
-20 to 100	275	720	1,440	230	600	1,220	230	600	1,200	230	600	N/A	230	600	1,200
200	235	620	1,240	195	505	1,015	200	520	1,045	200	525	N/A	205	540	1,080
300	215	560	1,120	175	455	910	190	490	980	190	490	N/A	195	505	1,015
400	195	515	1,025	160	415	825	190	490	980	180	475	N/A	185	480	960
500	170	480	955	145	380	765	170	490	980	170	470	N/A	170	455	910
600	140	450	900	140	360	720	140	490	980	140	470	N/A	140	440	880
650	125	445	890	125	350	700	125	490	980	125	435	N/A	125	425	850
700	110	430	870	110	345	685	110	490	980	110	405	N/A	110	420	840
750	95	425	855	95	335	670	95	490	980	95	405	N/A	95	415	825
800	80	420	845	80	330	660	80	490	980	80	405	N/A	80	410	815
850	65	420	835	65	320	645				65	325	N/A	65	400	795
900	50	415	830							50	245	N/A	50	395	790
950	35	385	775							25	120	N/A	35	385	775
1000	20	350	700										20	365	725
1050	20 *	345	685												
1100	20 *	305	610												
1150	20 *	235	475												
1200	20 *	185	370												
1250	20 *	145	295												
1300	20 *	115	235												
1350	20 *	95	190												
1400	20 *	75	150												
1450	20 *	60	115												
1500	15 *	40	85												

* Rating for weld-end valves.
Flanged End valves rated to 1000°F maximum

Use solution annealed material only
Not to be used over 1000°F maximum

Hydrostatic Shell Test Pressures

Class	150	300	600
Pressure	425	1,100	2,175

NOTE: These are design pressure ratings from ASME B16.34-1996 and apply to castings only. Packing and gasket materials may limit temperature range of specific products.

Stainless Steel Valves

Valve Marking System

It is important to properly identify valves in service to allow for the ordering of replacement parts or to address questions or concerns relating to Alloyco products. The valve marking system shown here will help customers identify valves accurately, speeding responses to customer service issues.

Valve Marking System Codes

AAAA	Material (CF3M, CF8M, etc.)
BBB	Size (1/2", 4", etc.)
CCC	Class (150, 300, 600)
DDD	Manufacturer ID Number
EEEEEEEEEE	Serial Number
FF	Foundry Number
GGGGGG	Heat Number

Gate Valve

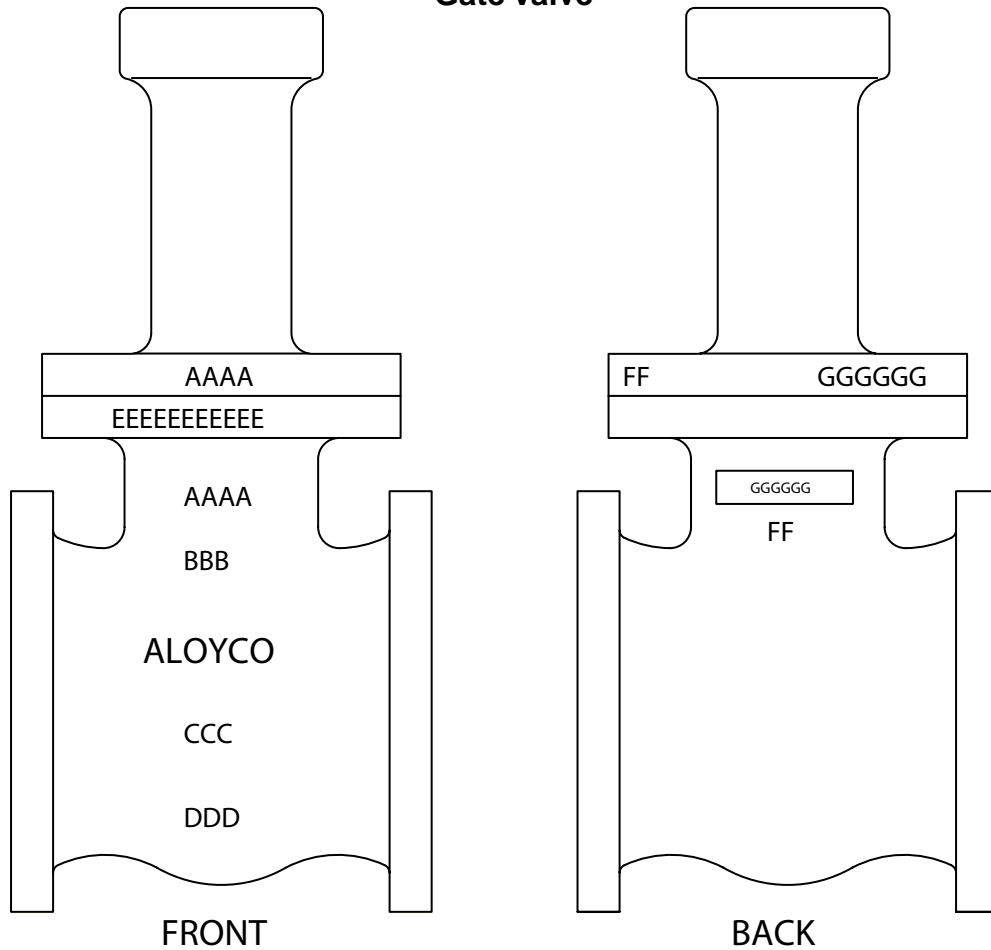

Stainless Steel Valves

Valve Marking System

Globe Valve

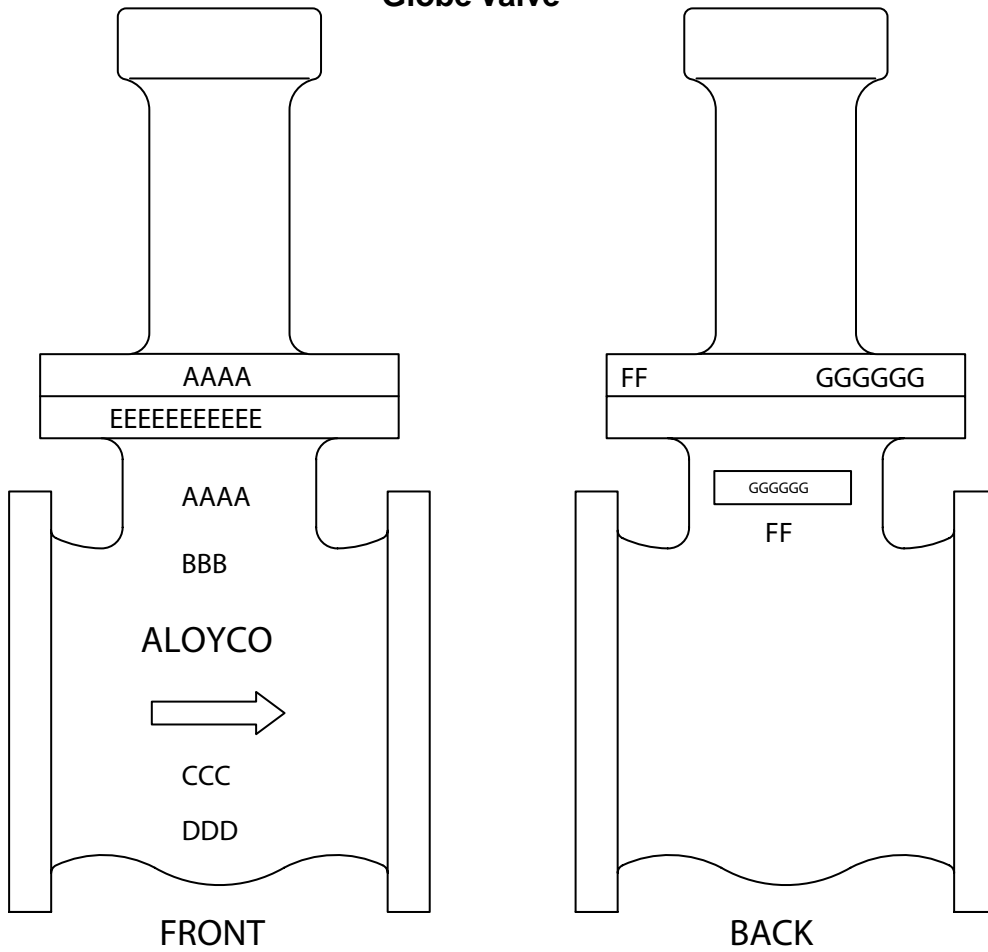

Check Valve

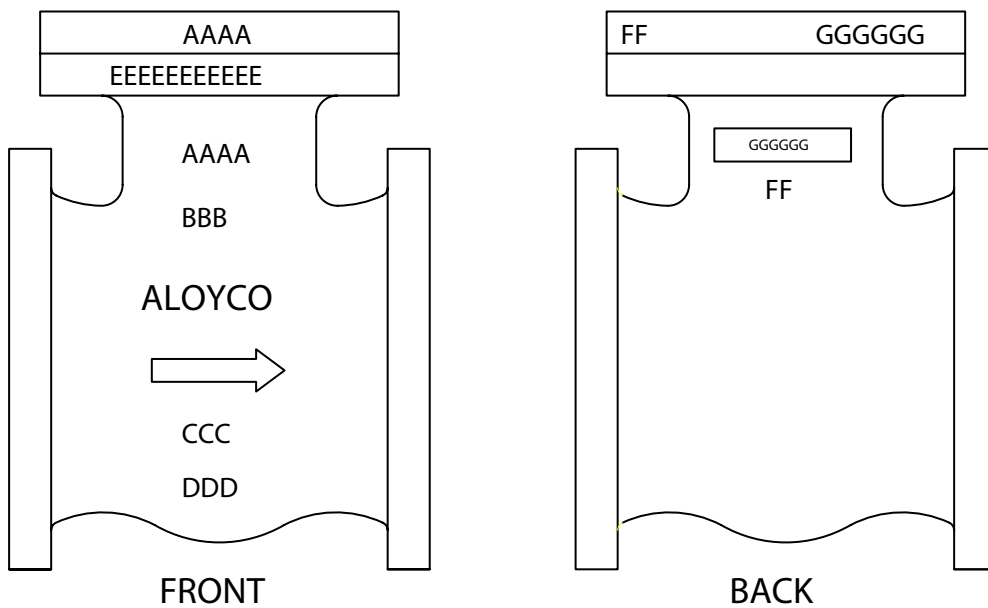

"WE WROTE THE BOOK"

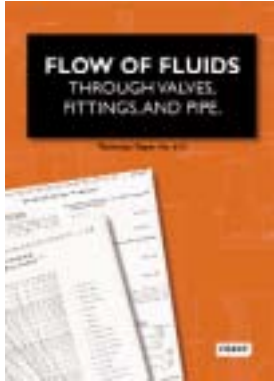

ALOYCO

2129 3rd Avenue, S.E.
Cullman, AL 35055
Tel: 800-786-2542
Fax: 256-775-3860

www.cranevalve.com

Aloyco is a trademark of Crane Co.

CRANE

THE VALVE EXPERTS